

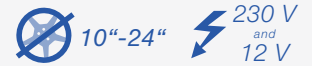

Wheel balancer hand operated | Item No.: TWF-100



**TWX-610 + TWF-100
also available as a set!**



**Only suitable for
our tyre changer
TWX-610!**

*Please consult our technical
decision-maker (on page 49) before
purchasing your wheel balancer (s)!*

Description

The TWF-100 is a perfect basic model that complements our tyre mounting machine TWX-610 with a wheel balancer (hand operated) in a top price-performance ratio. It is perfect for limited space. Handbrake for fixing the shaft during wheel mounting, balancing and braking. Power supply: 220 V and 12 V connection. Easy to use and innovative, space-saving design. **Only suitable for our tyre changer TWX-610.**

Features

- 1A Quality built with CE-Certificate
- Manufactured in accordance to ISO 9001
- Automatic balancing, manual wheel braking
- Handbrake for fixing the shaft during wheel mounting, balancing and braking
- Easy handling
- Solid construction
- Digital display
- Static and dynamic balancing
- Various programs selectable: Normal / Static / Alu1, Alu2, Alu3, Alu-S / Motorcycle etc.
- Integrated calibration and self-diagnostic program
- *Optional: Motorcycle adapter, diverse vehicle adapter*

Delivery contents

- Wheel balancer TWF-100
- Centering cones (4 pcs.) gauge, weight pliers
- Quick release nut, Pressure cup, Rubber lip
- Calibration weight | English instruction manual
- CE-Certificate
- **Assembly video online | Product video online**

Videos



Product
video



Assembly
video

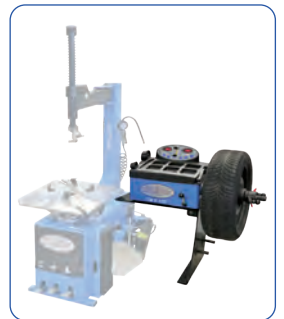
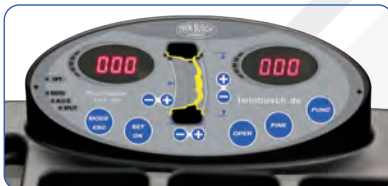

Dimensions

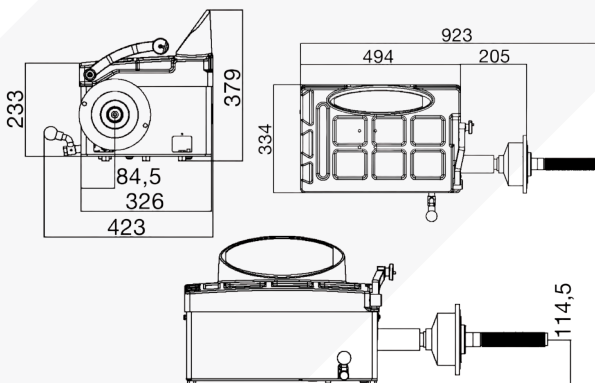

Delivery contents



Technical Data

Wheel width	1,5" - 20"
Wheel diameter	10" - 24"
Wheel weight (max.)	65 kg
Wheel center hole	36-105 mm
Measuring time (approx.)	8 sec.
Power supply	12 V and 230 V
Fusing	16 A / type C
Noise level	< 70 dB
Weight (approx.)	69 kg

Optional accessory

Motorcycle adapter
Item No.: TWF-MOTO



Self adhesive
balance
weights
Item No.:
TWF-KG

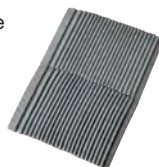

Further accessories can be found at www.twinbusch.co.uk