

Tyre changer

Item No.: TWX-93



Description

Top tyre changer with a new type of clamping system, optimal for sensitive aluminium rims. The wheel is mounted on a spindle using a centering cone (incl. 4 pcs.) and a quick-locking clamp in connection with a bayonet lock.

Features

- 1A Quality built with CE-Certificate
- Manufactured in accordance to ISO 9001
- Self centering wheel mounting system
- Mounting shaft with quick release system
- 1 Help-arm for professional use
- Wheel lifter
- Mounting head can be moved to the side
- Pneumatic mounting head adjustment
- Large clamping range for cars and vans
- High quality stainless steel components fitted inside
- Precise control block with STOP function
- Powerful bead breaker (2500 kg)
- Powerful electrical motor
- Comfortable and clear tyre inflator

Delivery contents

- Tyre changer with maintenance unit
- Air filler and lifting lever
- Bead press and edge protection
- Plastic protectors for aluminium rims (3 pcs.)
- *Assembly video online*
- *Product video online*



Comfortable and clear tyre inflator

Included

Bead press and edge protection included free of charge!



Check our technical decision helper (on page 38) before you buy your tyre changer!



Videos



Product video

Assembly video



Dimensions

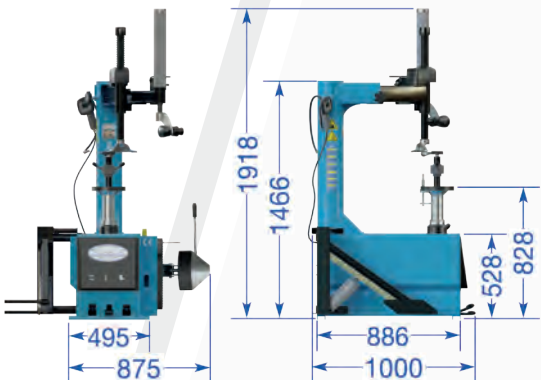

Delivery contents



Technical data

Wheel diameter (max.)	45" (1143 mm)
Wheel width (max.)	16" (406 mm)
Bead breaker force	2500 kg
Air supply	8-10 bar
Power supply	400 V
Motor power	0,75 kW
Fusing	16 A / type C
Noise level	<70 dB
Weight (approx.)	269 kg

Optional accessory

Roll board
Item No.: TWX-ROLL



Hole adapter
Item No.: TWX93-AD



Second help-arm
Item No.: TWX93-H



Tyre mounting paste
Item No.: TW1530MP



Further accessories can be found at www.twinbusch.co.uk