



WHEEL BALANCERS

TWF-23

Ø Wheel diameter: 10" (254 mm) - 24" (610 mm)

TWF-23

INSTALLATION, OPERATION AND MAINTENANCE MANUAL



Always read these operating instructions carefully before using the wheel balancer. Follow the instructions carefully.

Table of contents

1. General information	1
2. Identification of the operating instructions	1
3. Technical data	1
4. Modification of the product	2
5. Safety-related information	2
5.1 Safety instructions	2
5.2 Protective devices	2
5.3 Warnings	2
6. Conformity with the product	3
7. Technical specification	3
7.1 Machine description	3
7.2 System	3
8. Assembly and installation	4
8.1 Soil conditions	4
8.2 Assembly instructions	4
8.3 Fastening the wheel	6
9. Commissioning	7
9.1 Safety precautions	7
9.2 Description of the keyboard on the monitor	7
9.3 Description of the foot parking brake	8
9.4 Calibration	8
10. Wheel balancing programmes	9
10.1 Balancing programmes	9
10.2 Steel wheel with 2 impact weights	10
10.3 ALU 1 and ALU S (adhesive weights at 12 o'clock above axle)	11
10.4 ALU 1 and ALU S (adhesive weights at 12 o'clock above axle)	11
10.5 ALU 3, ALU 4 and ALU 5 (impact and adhesive weights)	12
10.6 Static balancing (motorbike)	12
10.7 Special mode for aluminium wheels	13
11. Troubleshooting	14
12. Maintenance	16
12.1 Maintenance by non-specialists	16
12.2 Maintenance by experts	16

12.3 *Correct handling of the quick-release nut and threaded axle*.....17

13.Appendix18

13.1 *Packing list*.....18

13.2 *Dimensions of the tyre balancer*18

13.3 *Circuit diagram CPU*19

13.4 *Circuit diagram*.....21

13.5 *Detailed drawing and parts description*.....22

Further attachment:

- **EU Declaration of Conformity**

Important information:

ASSEMBLY



You can find the assembly video for this machine on YouTube: <https://youtu.be/3zMcXwJGcqU> or scan the QR code.



PRODUCT PRESENTATION



You can find the product presentation video for this machine on YouTube: <https://youtu.be/KUgYBtxs8Ro> or scan the QR code.



CALIBRATION



You can find the calibration video for this machine on YouTube:
<https://youtu.be/1eDjKjjMGKA>
or scan the QR code.





TIPS & TRICKS



In the "Tips & Tricks" section, we show you simple solutions, in videos to make your TWIN BUSCH® products even more efficient to work. Our technical specialist will explain the exact steps to you.

<https://www.twinbusch.co.uk/Tips-Tricks: :74.html>

24/7 Service Center:



Our **24/7 Self-Service Centre** is a mobile website for self-diagnosis of problems with your Twin Busch lift, tyre changer or balancer. Here we offer you an extensive collection of videos covering a wide range of topics relevant to your Twin Busch product, from fine adjustment to maintenance and component replacement.

The **24/7 Self-Service Centre** is a versatile tool that helps you learn how to maintain and repair your Twin Busch lift, tyre changer or balancer yourself.

To open the page on your mobile device, please visit [twinbusch.com/qr](https://www.twinbusch.com/qr) or scan the QR code opposite.

For Twin Busch lifts delivered from mid-2020, you will also find the QR code on a sticker on the control box.

1. General information

The automatic **TWF-23** tyre balancer is equipped with an electric feeler arm for rim distance and rim diameter. Precise application of all hidden adhesive weights using the electric feeler arm. The TW F-23 has a 40 mm shaft and an extended wheel holder for better balancing of wide tyres, e.g. Porsche, SUV, etc. A foot brake for fixing the shaft during wheel clamping or unbalance correction and a feeler arm with visual/acoustic operator guidance. As well as a new extra large 7.5 inch digital display for clear working.

Special features of the product:

- Manufactures according to **ISO 9001**
- Top design and robust technology
- Shaft diameter 40 mm for a more accurate balancing
- 255 mm shaft for better balancing of wide rims
- Digital display 7.5 inches
- Foot brake for fixing the shaft when balancing
- Automatic measurement process and wheel brake
- Static and dynamic balancing
- Various selectable programs Normal / Static / Alu1, Alu2, Alu3, Alu4 and Alu5 / motorcycle etc.
- Optional: Motorcycle adapter, Adapter for vehicles without center hole

2. Identification of the operating instructions

Operating instructions for the **TWF-23**

of Twin Busch GmbH Ampèrestrasse 1, D-64625 Bensheim Phone: +49 6251-70585-0 Telefax: +49 6251-70585-29 Internet: www.twinbusch.de Email: info@twinbusch.de	Twin Busch UK Ltd. 9, Linnell Way Telford Way Industrial Estate NN16 8PS, Kettering (Northants) Phone: +44 (0) 1536 522 960 Internet: www.twinbusch.co.uk Email: info@twinbusch.co.uk
---	---

Status: -00, 10.01.2025

File: TWF-23_Tyre_Wheel_Balancer_Manual_uk_00_20250110.

3. Technical data

Rim width	1.5" (38 mm) to 20" (508 mm)
∅ Rims	10" (254 mm) to 24" (610 mm)
Wheel weight max.	65 kg
∅ Rim centre hole	40-135 mm
Measurement tolerance	+/- 1g
Measuring time	4-7 sec.
Drive voltage	230 V
Protection	16 A (C/sluggish)
Noise level	<70 dB
Dead weight	123 kg
Drive shaft length	255 mm
Rim tension	Manual

4. Modification of the product

Improper use, modifications, conversions and attachments of the tyre balancer and all its components that have not been agreed with the manufacturer are not permitted. The manufacturer accepts no liability for improper installation, operation or overloading. Improper use also invalidates the CE certification and the validity of the certificate.

If you require any changes, please contact your dealer or the expert staff at Twin Busch GmbH beforehand.

5. Safety-related information

Read the operating instructions carefully before operating the tyre balancer. Keep the instructions for future reference. Follow the instructions exactly to achieve the best performance from the machine and to avoid damage caused by personal negligence.

Check all connections and components thoroughly for damage.

5.1 Safety instructions

We accept no liability for damage caused by improper installation and operation, overloading or unsuitable ground conditions.

- Read the manual carefully before using the machine. The machine must not may only be used by trained personnel and only for the purpose described in this manual.
- Check the voltage and frequency specified on the rating plate.
- The wiring may only be carried out by an electrician.
- Do not wear inappropriate clothing, such as loose-fitting garments with loose hanging parts, etc., which could get caught in the moving parts of the machine.
- Do not modify the machine without the manufacturer's consent.
- Do not use a strong jet of compressed air for cleaning.
- Clean the plastic surfaces with plastic cleaner. Make sure that no liquid gets inside the machine to avoid damaging the circuit boards.
- If the machine will not be used for a longer period of time, disconnect it from the power supply.

5.2 Protective devices

- Level, horizontal, solid floor, preferably made of concrete or with tiles.
- Protected from the weather.
- Pollutant-free area.
- The workplace must not be exposed to dangerous movements caused by other machines in operation.
- Explosive, corrosive and/or toxic materials should not be stored in the same place.
- From the control station, the operator must be able to see the entire appliance and the surrounding area. Within the area, you must prevent access to unauthorised persons and objects that could be a source of danger.
- All installation work relating to the connection to the power supply (in particular the power supply) must be carried out by professionally qualified persons.

5.3 Warnings

The warning signs must be kept clean and replaced if they are damaged or missing. Please read the signs carefully and memorise their meaning for future use.

6. Conformity with the product

The TWF-23 tyre balancer is CE-certified and complies with the Machinery Directive 2006/42/EC and fulfils the EN ISO 12100:2010 standard. See also the EU Declaration of Conformity at the end of the operating instructions.

7. Technical specification

7.1 Machine description



7.2 System

1. The computing unit consists of a powerful CPU, a mainboard, a high-resolution graphics card, a soft-touch keyboard and an LCD screen.
2. Electronic measuring ruler.
3. Position detection by means of an opto-electronic coupler.
4. 2-phase asynchronous motor for controlled rotation.
5. Horizontal and vertical pressure sensor and protective hood function. Schematics of the interrelated working factors of the machine

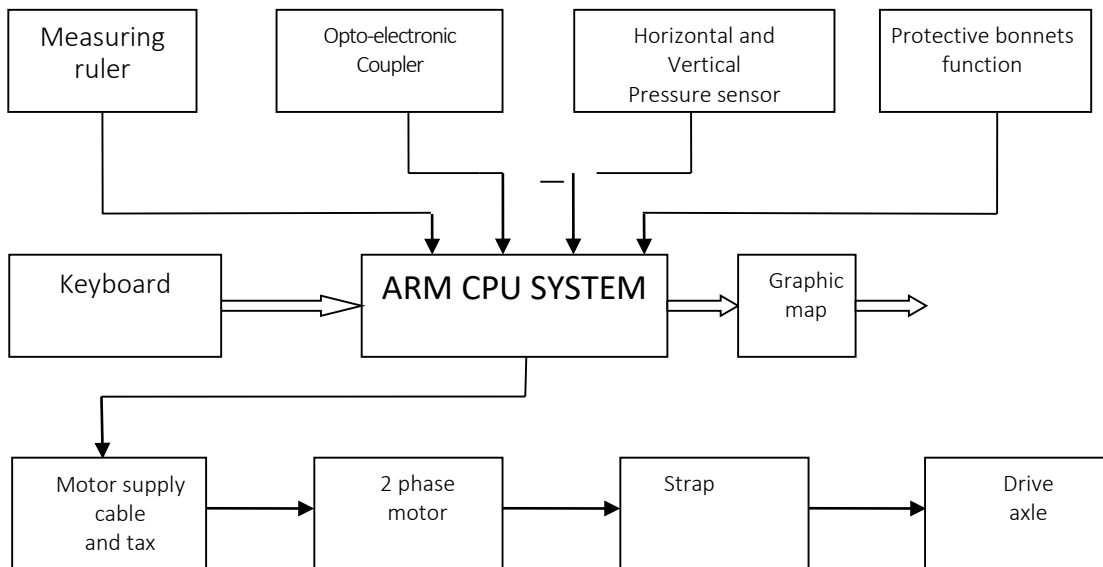

8. Assembly and installation

8.1 Soil conditions

- The tyre balancer must be set up on firm concrete or a similarly solid surface; a soft or vibrating surface can cause measurement errors.
- There should be a free space of 50 cm around the machine so that it can be operated comfortably. The safety regulations for the work area must also be observed.
- Fasten the anchor bolts through the mounting hole of the tyre balancer in the foundation to ensure safe and accurate operation.

8.2 Assembly instructions

- 1) Open the packaging and remove the wooden frame with a hammer.
- 2) Remove the packaging film and remove the small parts.
- 3) Open the box containing the small parts and put them to one side.
- 4) The machine is fixed to the pallet with three screws. Remove these and slide the machine off the pallet.
Note: Pay attention to the shaft on the balancing machine when pushing

- 5) Fit the cone brackets.



Illustration: Cone mounts

- 6) Fit the shaft.
a) Tighten the Allen screw in the shaft securely.



Illustration: Shaft

- b) You can place the remaining cone on the shaft.
c) Place the clamping pot with tamping rubber on the wing nut. Then place the wing nut on the shaft.

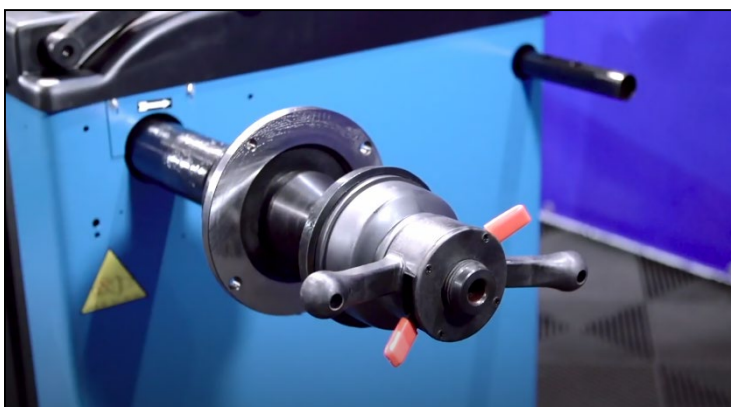

Illustration: Wing nut

- 7) Fit the protective bracket.
From the front, use the left hole.
Note: You will need the right-hand hole if you are using a motorbike adapter for the machine.
- 8) Place the plug on the end of the protective bracket.

- 9) Screw the two parts of the protective cover together. Use the special spanner supplied to hold the nuts in place.
- 10) Use the small self-tapping screws to snap the protective cover onto the bracket.

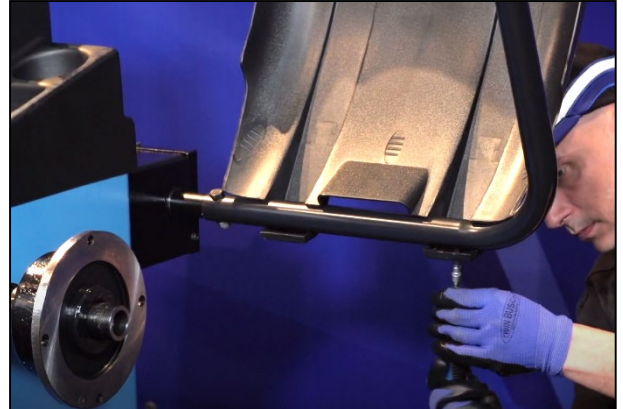
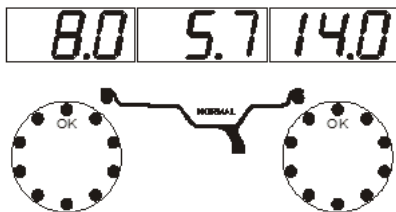

Illustration: Screwing on the protective cover

- 11) Then anchor the machine to the ground to ensure optimum balancing operation.
Caution: After switching on the power, the machine automatically starts the balancing process when the protective cover is closed.
- 12) After switching on, the machine requires approx. 3 seconds to perform an automatic initialisation and switches to dynamic mode. The following default values appear on the display:



8.3 Fastening the wheel

Check that you have removed all old weights and cleaned the wheel. If necessary, correct the prescribed tyre pressure in order to fit the wheel.

Select the appropriate cone.

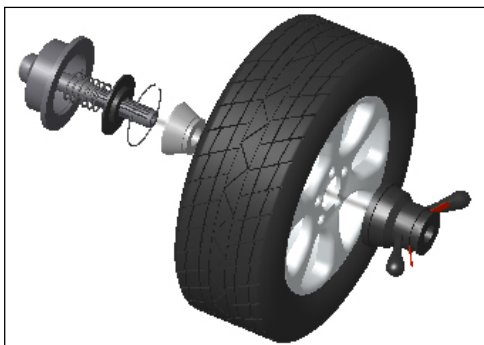

Illustration: Method A - cone inside

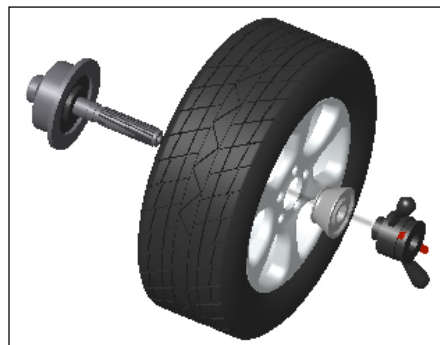

Illustration: Method B - external cone

Note: Place the wheel carefully on the threaded rod! (Do not slide back and forth with the centre hole of the wheel on the threaded rod). This can damage the threaded rod in the long term.

9. Commissioning

9.1 Safety precautions

- If the safety devices are defective or show abnormalities, the machine must not be put into operation under any circumstances!
- Check that all connections are tight and functional.

9.2 Description of the keyboard on the monitor

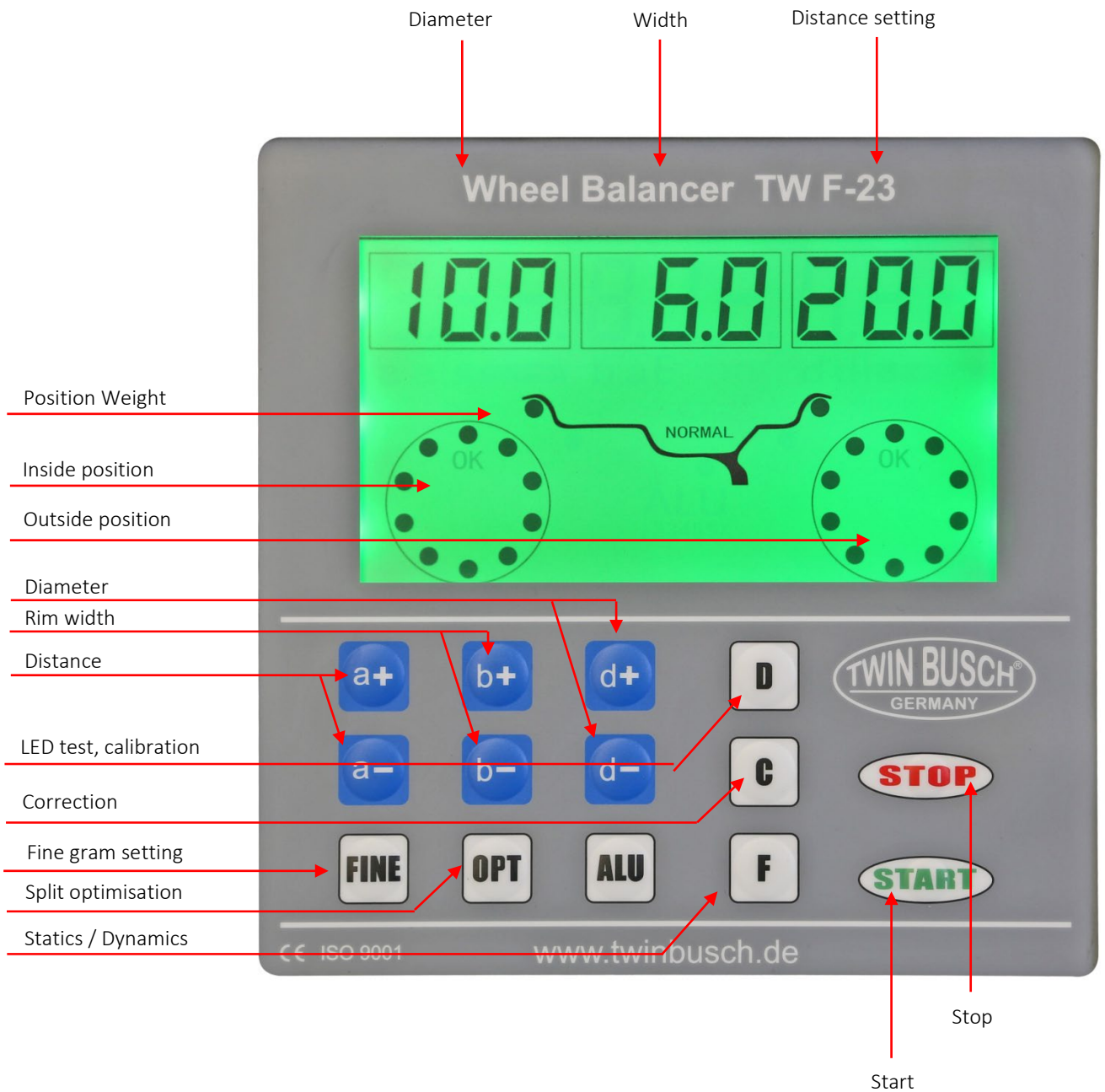

Caution: Only press the press studs with your fingers. Never use sharp objects.

9.3 Description of the foot parking brake



The foot parking brake is used to hold the shaft in place during unbalance correction or wheel clamping.

9.4 Calibration

9.4.1 Distance gauge

- a) Mount any wheel on the shaft, even if it is not balanced, although it is advisable to use a wheel with "average" dimensions.
- b) Press **STOP** and **FINE** to start the calibration of the distance gauge.
- c) Hold the measuring gauge at position 0 and confirm with the **ALU** button.
- d) Then hold the measuring gauge at position 15 and confirm again with the **ALU** button.
The distance gauge is now calibrated.

9.4.2 Diameter gauge

- a) We now need the rim diameter of the clamped wheel.
- b) Press **STOP** and **OPT** to start the calibration of the diameter gauge.
- c) Use the **d+** and **d-** buttons to set the existing rim diameter.
- d) Confirm with the **ALU** button.
- e) **Note: Make sure that the machine's feeler arm is turned the right way round.**
Place the feeler arm on the rim flange and confirm with the **ALU** button
The diameter gauge is now calibrated

9.4.3 Unbalance sensors

The tyre must now be completely calibrated. Measure the rim width using the width gauge supplied.

- a) Enter the rim width in the machine using the **b+** and **b-** buttons.
- b) Read the distance and rim diameter with the feeler arm. Make sure that the machine is in the normal programme.
- c) Start the calibration by pressing the **D** and **C** buttons simultaneously.

Note: The machine first measures the general unbalance.

- d) Now strike the test weight at any position on the outside. Close the protective cover. **Note: The machine now measures the difference to the first pass**
- e) This completes the calibration. Remove the test weight.

10. Wheel balancing programmes

10.1 Balancing programmes

The available balancing programmes show where the correction weights should be placed.



Steel or lightweight aluminium rims by attaching clamping weights on the rim edges.



Required for motorbike wheels or if the weights cannot be fitted on both sides of the rim.



Balancing lightweight aluminium rims by attaching adhesive weights on the rim edge.



Balancing of aluminium rims by concealed attachment of the outer rims Adhesive weights. Attach the outer weight as shown in the Illustration shown to.



Combined balancing: Clamping weight on the inside, Hidden attachment of the adhesive weight on the outside.



Combined balancing: Clamping weight on the inside,
Hidden attachment of the adhesive weight on the outside.



ALU S

Balancing of rims with unusual shapes.

10.2 Steel wheel with 2 impact weights

The machine is ready for data input.

- 1) Pull the measuring ruler to the rim flange to determine the values A and D. Then return to the rest position. Values A and D appear on the display. You can use the measuring gauge to determine the wheel width and enter it into the machine using the **b+** and **b-** buttons.
- 2) Close the bonnet. The machine starts up. When the machine stops, you can open the bonnet again. Turn the inside and outside to the black circle (see **Illustration**) and hit the weights over the axle at 12 o'clock.

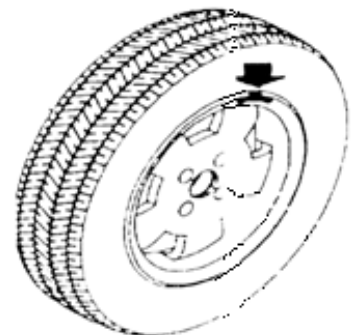
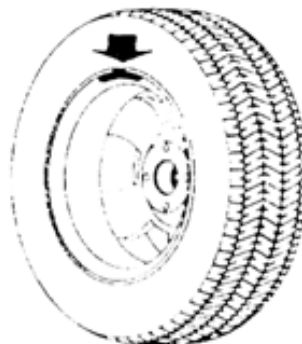

- 3) Close the bonnet again (to check opening). The display shows 0 g inside and outside.
Note: 5 g is the tolerance limit.

10.3 ALU 1 and ALU S (adhesive weights at 12 o'clock above axle)

- 1) Drag the ruler to the FI point and hold it. The signal tone confirms the entry.

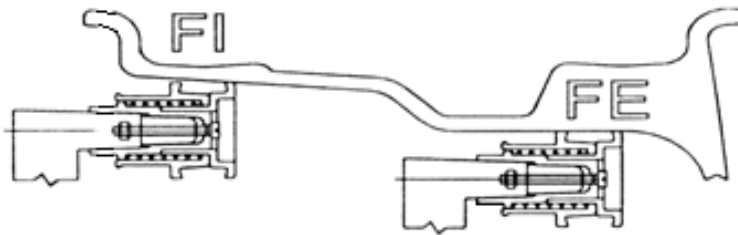

- 2) Now drag the ruler further to point FE and hold it. The signal tone confirms the entry.
- 3) Place the ruler in the rest position and close the bonnet. The machine starts up. When the machine stops, you can open the bonnet again.
- 4) Turn the inside and outside onto the black circle (see **Illustration**) and hit the weights over the axle at 12 o'clock.



- 5) Close the bonnet again (to check opening). The display shows 0 g inside and outside.
Note: 5 g is the tolerance limit.

10.4 ALU 1 and ALU S (adhesive weights at 12 o'clock above axle)

- 1) Pull the ruler to the left-hand rim flange and hold it there. The signal tone confirms the entry.
- 2) Now drag the ruler to point FE (as in 10.3) and hold it. The acoustic signal confirms the entry.
- 3) Place the ruler in the rest position and close the bonnet. The machine starts up. When the machine stops, you can open the bonnet again.
- 4) Turn the inside and outside onto the black circle (see **Illustration**) and hit the weights over the axle at 12 o'clock.



10.5 ALU 3, ALU 4 and ALU 5 (impact and adhesive weights)

- 1) Guide the ruler to the rim flange to determine the values A and D.
- 2) Use the measuring gauge to determine the rim width and enter the values with b+ and b+ in the machine.
- 3) Close the bonnet. The machine starts up.
- 4) When the machine stops, press **ALU** until the **ALU 3** screen appears on the monitor.

Note: The same applies to ALU 4.



10.6 Static balancing (motorbike)

- 1) After switching on, press the F button.



- 2) Pull the measuring ruler to the centre of the wheel and hold it. The measured values are accepted.
- 3) Close the bonnet and wait until the machine stops again. Then open the bonnet again.
- 4) Both circles rotate at the same time. Attach the weights.

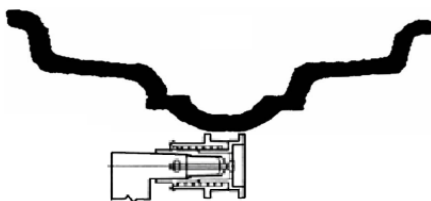

10.7 Special mode for aluminium wheels

- 1) Drag the ruler to the FI point and hold it. The signal tone confirms the entry.

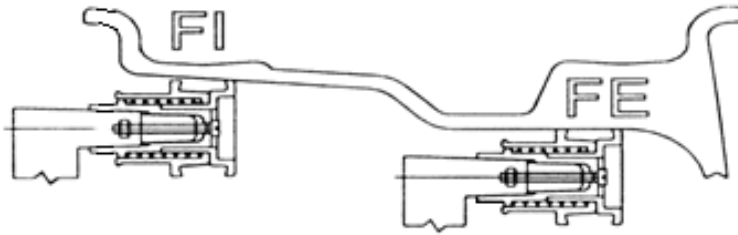

- 2) Now drag the ruler further to point FE and hold it. The signal tone confirms the entry.
- 3) Place the ruler in the rest position and close the bonnet. The machine starts up. When the machine stops, you can open the bonnet again.

- 4) Press STOP and ALU in succession. The display shows in the centre field:

(---) = Alu Spezial Modus eingeschaltet!

- 5) Turn the wheel by hand until the black circle is complete. Place the weight in the device of the ruler and then pull it out again until the horizontal black lines in the display are complete.

Inside:

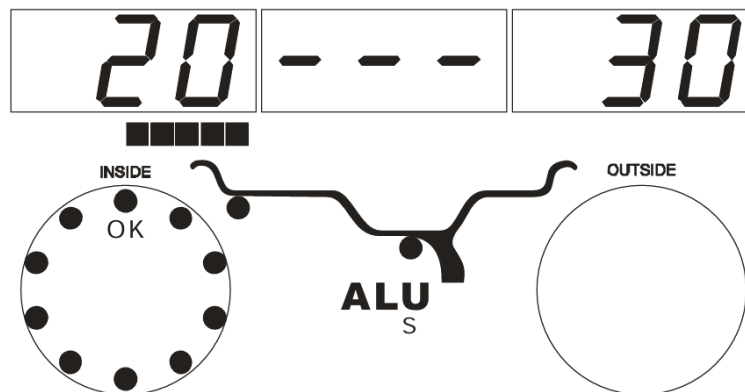

Exterior:

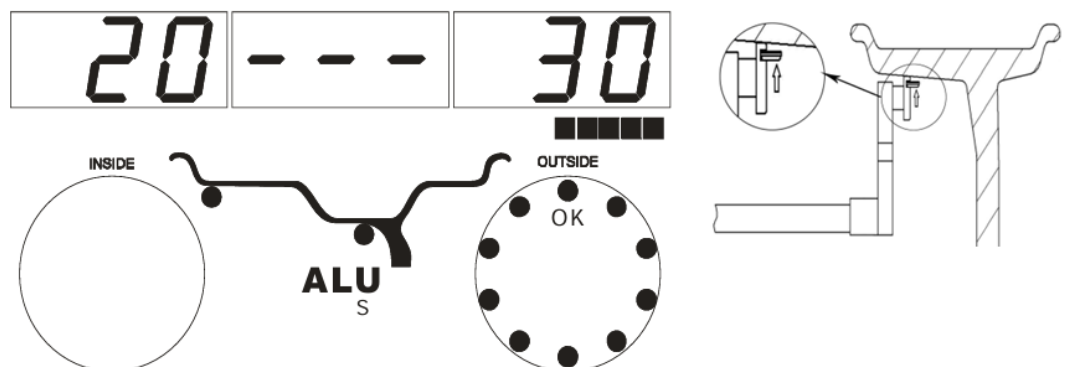

11. Troubleshooting

Please note: Do not hesitate to contact the expert staff at Twin Busch GmbH if you are unable to rectify a fault yourself. We will be happy to help you solve the problem. In this case, please document the fault and send us pictures and a precise description of the fault so that we can identify and rectify the cause as quickly as possible. The following table lists possible errors, their cause and the associated troubleshooting for quicker identification and self-remedy.

PROBLEM	CAUSE	SOLUTION
No message from the position sensor.	Position sensor defective.	Repair or replace.
	Motor does not run.	Restart the motor.
	Wheel locked.	Remove the blockage.
	Flat belt defective or loose.	Retighten or replace.
The speed is less than 60 rpm.	Unintentional braking of the wheel.	Check the brake mechanism.
	Loose flat belt.	Retighten or replace.
	No tyre fitted.	Fitting tyres.
Miscalculation.	Self-calibration faulty.	Repeat self-calibration.
	Unbalance value too high.	Is the wheel mounted correctly?
	Data memory defective.	Replace data memory.
Motor rotates in the wrong direction.	Cable connection incorrect.	Reverse the connection.
Protective cover open.	Protective cover open.	Close the protective cover.
	Protective cover switch defective.	Replace the protective hood switch.
Memory card faulty.	Self-calibration faulty.	Repeat self-calibration.
	Circuit board defective.	Replace the circuit board.
Self-calibration memory faulty.	100 g weight has not been added.	100 g weight.

Code	Meanings	Cause	Remedy
Err 1	Principal axis not spin or have not spin signal.	<ol style="list-style-type: none"> 1. Motor fault. 2. Position sensor fault. 3. Power supply board fault. 4. Computer board fault. 5. Connection-peg untouched. 	<ol style="list-style-type: none"> 1. Change motor. 2. Change position sensor. 3. Change power supply board. 4. Change computer board. 5. Check cable connections.
Err 2	The rotation is lower than 60r/min.	<ol style="list-style-type: none"> 1. Position sensor fault. 2. Wheel not impacting or weight too light. 3. Motor fault. 4. Driving belt too loose or too tighten. 5. Computer board fault. 	<ol style="list-style-type: none"> 1. Change position sensor. 2. Repeat impacting wheel. 3. Change motor. 4. Adjust driving belt elasticity. 5. Change computer board.
Err 3	Miscalculation.	tToo high imbalance.	Repeat the self-calibration change computer board.
Err 4	Principal axis Wrong rotation direction.	<ol style="list-style-type: none"> 1. Position sensor fault. 2. Computer board fault. 	<ol style="list-style-type: none"> 1. Change position sensor. 2. Change computer board.
Err 5	Protection hood not lay down.	<ol style="list-style-type: none"> 1. When press START key. Protection hood not lay down. 2. Jiggle switch fault 3. Computer board fault. 	<ol style="list-style-type: none"> 1. Follow right method operation. 2. Change jiggle switch. 3. Change computer board.
Err 6	Sensor signal transact circuit not working.	<ol style="list-style-type: none"> 1. Power supply board fault. 2. Computer board fault. 	<ol style="list-style-type: none"> 1. Change power supply board. 2. Change computer board.
Err 7	Lose date of interior.	<ol style="list-style-type: none"> 1. Incorrect self-calibration. 2. Computer board fault. 	<ol style="list-style-type: none"> 1. Repeat the self-calibration. 2. Change computer board.
Err 8	Self-calibration memory fault.	<ol style="list-style-type: none"> 1. Not put 100 gram on the rim when self-calibration. 2. Power supply board fault. 3. Computer board fault. 4. Pressure sensor fault. 5. Connection-peg untouched. 	<ol style="list-style-type: none"> 1. Follow right method repeat self-calibration. 2. Change power supply board. 3. Change computer board. 4. Change Pressure sensor. 5. Check cable connection.

12. Maintenance

12.1 Maintenance by non-specialists

Please switch off the power supply before carrying out maintenance.

1. Disassembly Please switch off the power supply before carrying out maintenance.
2. Check that the electrical cables are connected correctly.
3. Check whether the pressure screw of the main axle is loose.
4. The lock nut cannot secure the wheel to the main axle
5. Use the hexagon spanner to tighten the pressure screw of the main axle.

12.2 Maintenance by experts

Maintenance by specialists can only be carried out by specialists.

12.2.1 If the imbalance of the tested wheel is obviously incorrect and even after the self-calibration does not improve, this proves that the parameters of the machine have changed and the user should consult a specialist.

12.2.2 The pressure sensors should be replaced and adjusted according to the following and carried out exclusively by specialists.

Proceed as follows:

1. Loosen the nuts 1, 2, 3, 4 and 5.
2. Remove the sensor and the nut.
3. Replace no. 6 and 7, the sensor.
4. Install the sensor and the nut. **Note: Pay attention to the alignment of the sensor.**
5. Tighten nut no. 1 hand-tight.
6. Tighten nut no. 2 on the main axle and the side of the cabinet and tighten nut no. 3 hand-tight.
7. Tighten nut no. 4 hand-tight and no. 5 firmly.

12.2.3 The replacement of the circuit board and the components on it should be carried out by specialists.

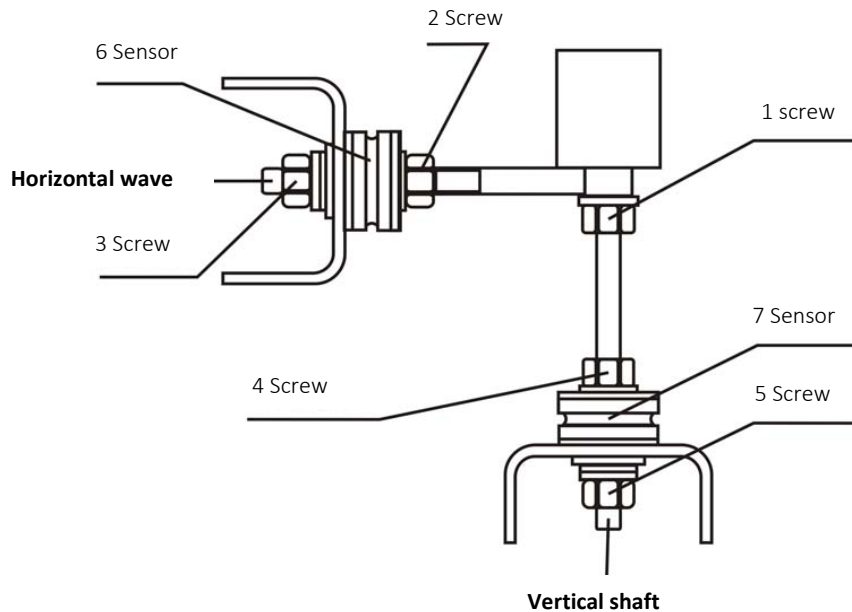

If you follow the above maintenance activities, your machine will remain in good condition and damage and accidents will continue to be avoided.

12.3 Correct handling of the quick-release nut and threaded axle

The quick-release nut is a wearing part, as is the threaded axle on which it is tightened. To ensure a long service life of the quick-release nut, the tension of the tightened quick-release nut should be removed before removing it as follows

the tightened quick-release nut as follows before removing it:

Loosen the quick-release nut by hand (two to three turns). The tension is thus removed. Then press and hold the red release levers and pull off the quick-release nut.

Never press the release under tension, as this will permanently damage the threads!

When mounting and removing the wheel on the threaded axle, there should be as little contact as possible with the wheel centre hole. However, this is unavoidable and does not lead to faster wear of the axle. Both parts (quick-release nut and threaded axle) can be ordered from your TWIN BUSCH service centre. Please let us know the diameter of the threaded axle in millimetres.

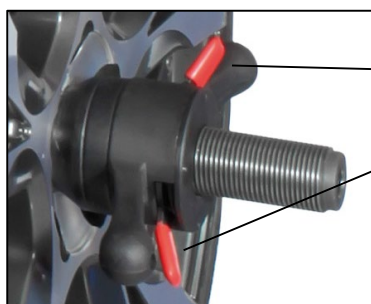

Press and hold simultaneously while pulling off the quick-release nut.

13. Appendix

13.1 Packing list

Name	Quantity
Threaded axle	1
Balancing weight tongs	1
Allen key	1
Gauge	1
Quick-release nut, bell	1
Clamping ring	1
Centring cones	4
Balancing weight (100 g)	1
Protective hood device (rod + bonnet + screw set)	1

13.2 Dimensions of the tyre balancer

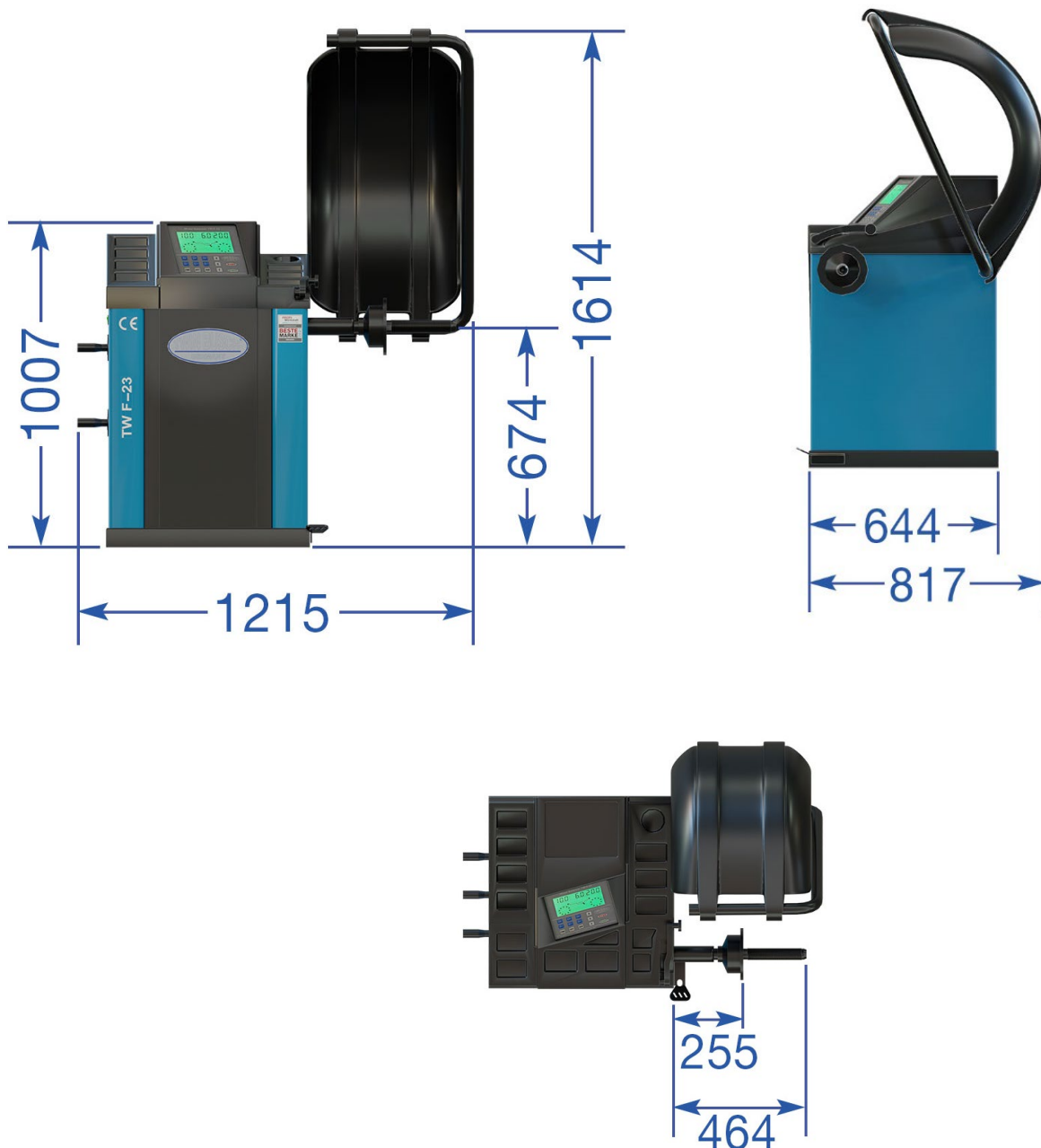

13.3 Circuit diagram

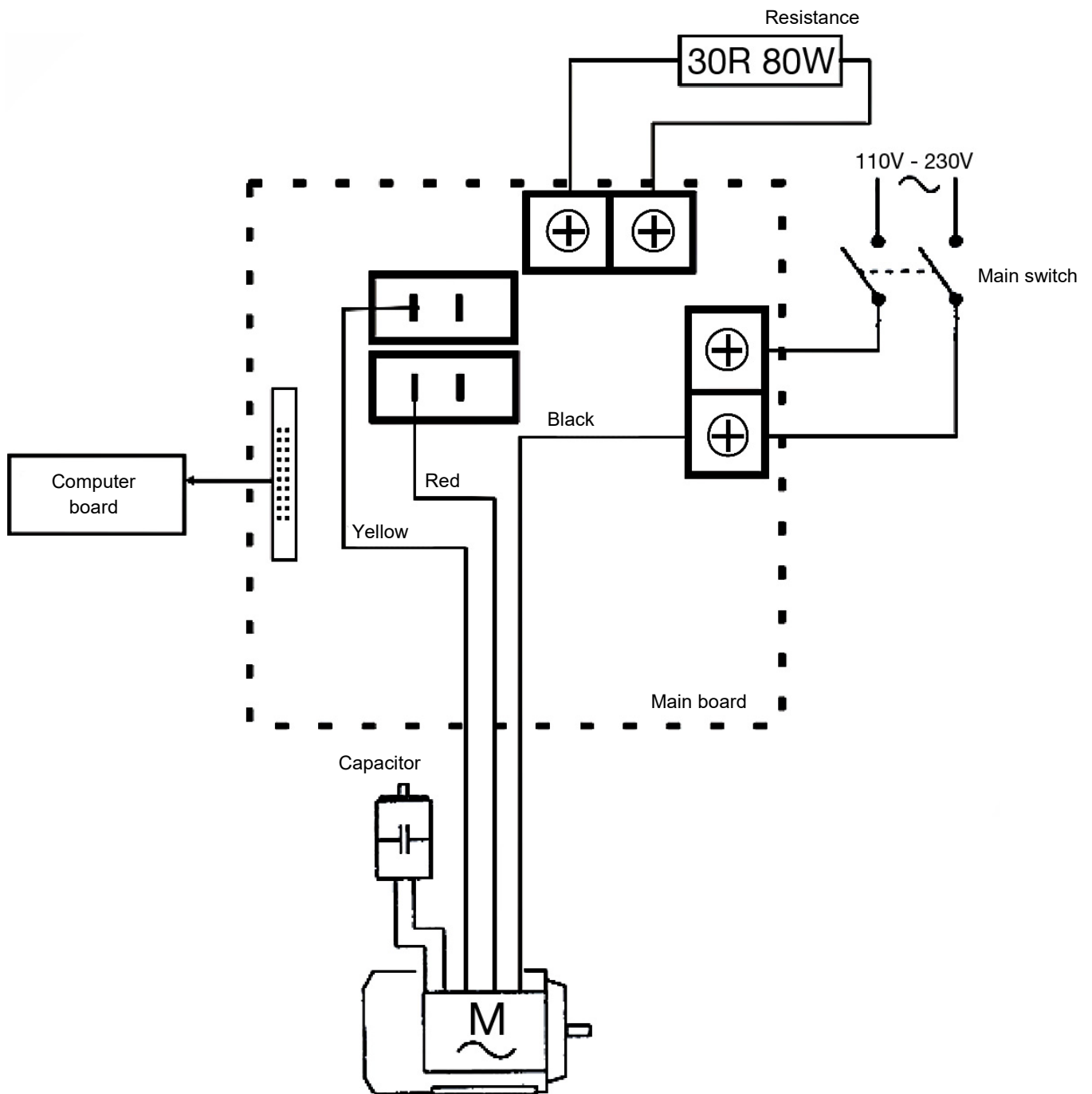

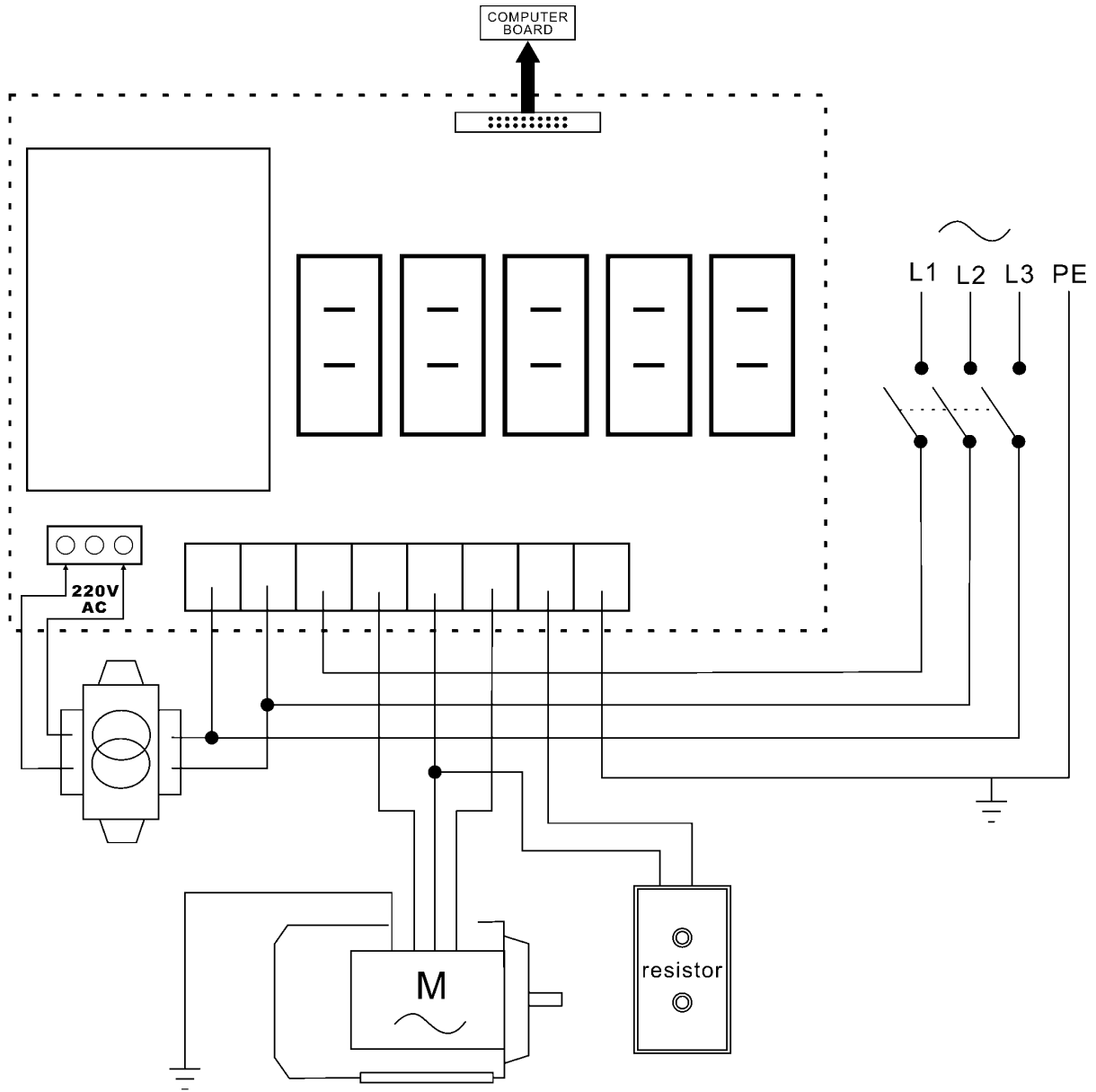

13.4 Circuit diagram

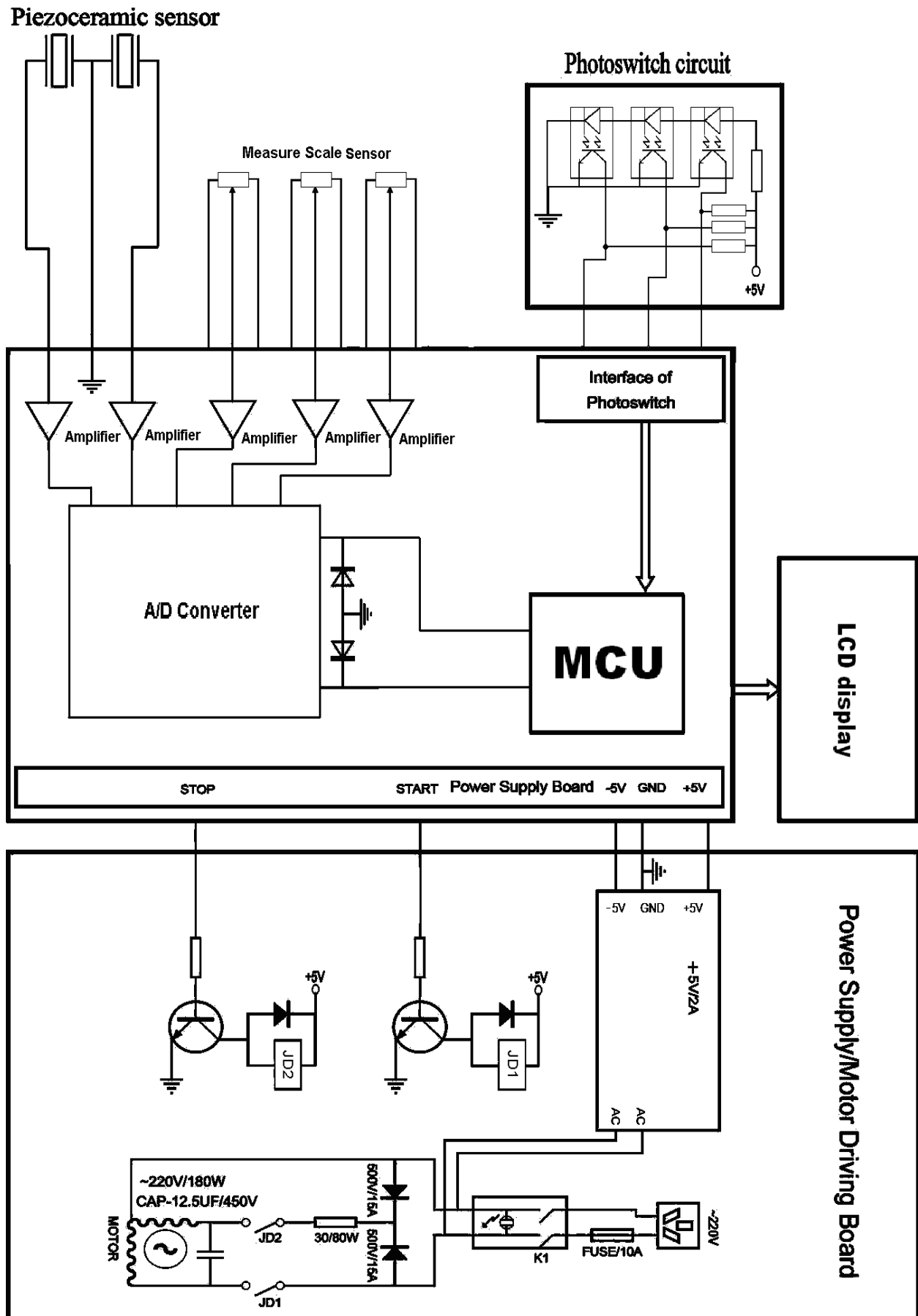

13.5 Detailed drawing and parts description

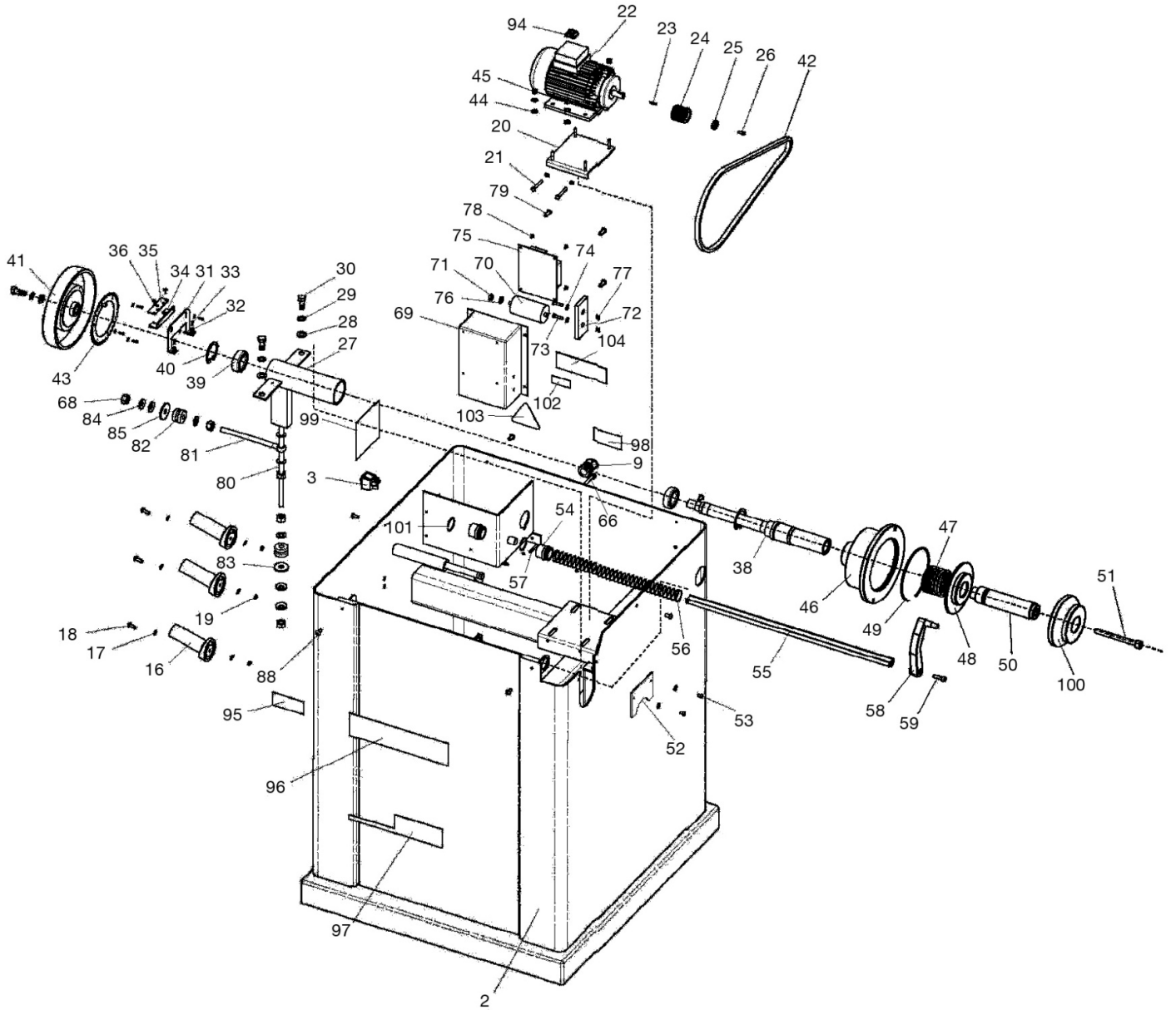

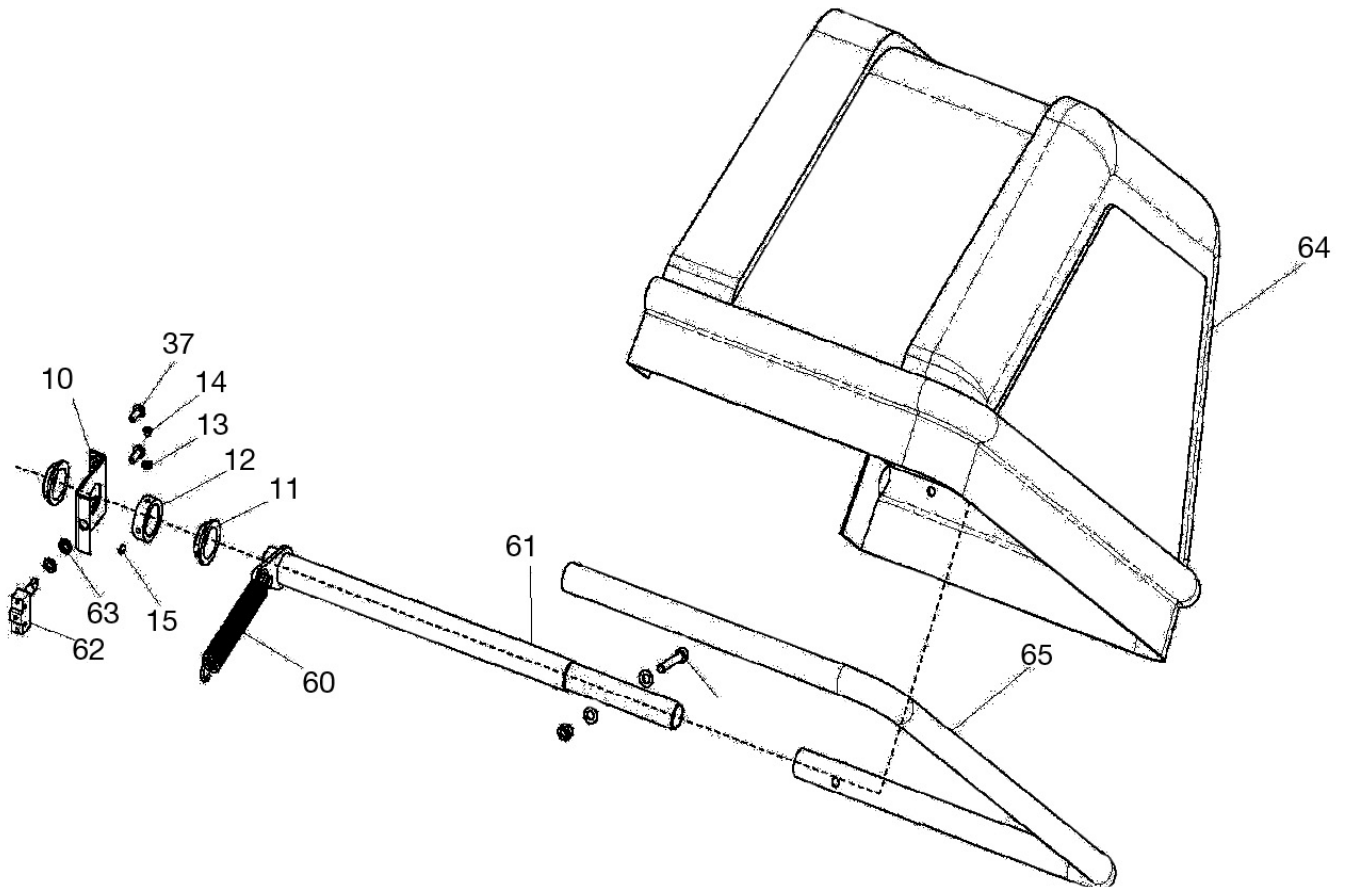
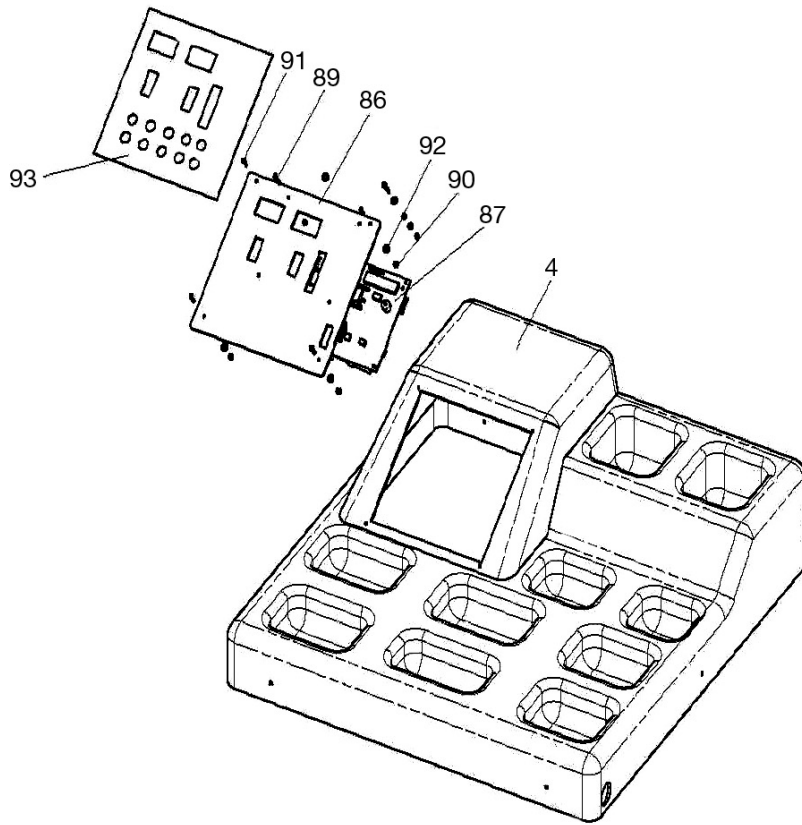

S/N	Name	Quantity	S/N	Name	Quantity
1	Manual ASM	1	55	Ruler	1
2	Frame 800	1	56	Tension spring for ruler	1
3	Switches	1	57	Snap pin	1
4	Cover	1	58	Ruler handle	1
9	Wire tube	1	59	Base screw M6x20	1
10	Support plate 1 for shielding	1	60	Spring for drive shaft	1
11	Socket for shielding shaft	2	61	Drive shaft	1
12	Locked socket	1	62	Microswitch	1
13	Washer M6	1	63	Nut for microswitch	2
14	Flat head screw M6x12	1	64	Shielding	1
15	Set screw M6	1	65	Support tube	1
16	Cone mounts	3	66	Hexagon head screw M6x35	1
17	Washer for M5	8	67	Cheese head screw M10x58	1
18	Flat head screw M5x15	3	68	Nut M10	6
19	Nut M5	5	69	Switch box cover	1
20	Motor adjustment plate	1	70	Capacity	1
21	Hexagon head screw M5x35	2	71	Nut M8	1
22	motor	1	72	Resistance	1
23	key	1	73	Flat head screw M5x25	2
24	Pulley for motor	1	74	Washer for M5	2
25	End cap	1	75	Printed circuit board	1
26	Cheese head screw M4x12	1	76	Washer for M8	1
27	Shaft bushing	1	77	Nut M5	2
28	Washer for M10	9	78	Flat head screw M3x7W	4
29	Spring washer-M10	3	79	Truss-head bolt M5x16	4
30	Hexagon head screw M10x25	3	80	Drive screw M10	1
31	Housing for the light barrier	1	81	M10 screw for Pioelektrik switch	1
32	Washer M3	7	82	Pioelectric switch	2
33	Cheese head screw M3x10	7	83	Small washer 11x30x3	1
34	Light barrier 1	1	84	Batterfly disc for M10	4
35	Light barrier circuit board	1	85	Large washer 11x38x3	1
36	Cap nut M3x10W	2	86	Printed circuit board mounted panel	1
37	Truss-head bolt M8	2	87	Main board	1
38	Drive shaft	1	88	Flat round head M5x12	6
39	Warehouse	2	89	Countersunk head screw M3x25	4
40	Spring washer	2	90	Nut M3	16
41	Belt pulley	1	91	Countersunk head screw M3x16	4
42	Strap	1	92	Washer for M4	4
43	Bevel gearbox	1	93	Keyboard	1
44	Toothed disc for M6	8	94	Wire-mounted base	1
45	Nut M6	4	95	Celabel	1
46	Drive flange	1	96	Unitelabel	1
47	Spring for extractor	1	97	Model label	1
48	Pressure cap	1	98	Qclabel	1
49	Spring washer	1	99	Circuitlabel	1
50	Drive screw	1	100	Cone	1
51	Cheese head screw M10x100	1	101	Seegerring	2
52	Boundary plate	1	102	220 V	1
53	Flat head screw M5x7	2	103	Warning	1
54	Standard socket	2	104	Type plate	1



The company

Twin Busch GmbH | Amperestr. 1 | D-64625 Bensheim

hereby declares that the **Wheel Balancer**

TWF-00, TWF-23, TWF-95, TWF-100, TWF-50T, TWF-150

(PL-1800, PL-1823, PL-1895WR, PL-1100, PL-1850, PL-1150)

Serial number:

in this configurations we have placed on the marked complies with the relevant essential health and safety requirements of the following EC-directive(s) in its/their current version(s).

EC-directive(s)

2006/42/EC

machines

Applied harmonized standards and regulations

**EN ISO 12100:2010
design**

Safety of machinery - General principles for

CE Certificate

M.2021.206.C65382

date of issue: 09.06.2023

place of issue: Ankara

technical file no.: MD-TCF-210601-31312

Certification body

UDEM International Certification,
Mutlukent Mahallesi 2073 Sokak (Eski 93 Sokak) No: 10,
Çankaya - Ankara - Turkey

Notified Body Appointment No.: 2218

In the case of improper use, as well as in the case of assembling, modification or changes which are not agreed with us, this declaration will lose its validity.

Authorized person to compile technical documentation is: Michael Glade (address as below)



TWIN BUSCH GmbH
Amperestr. 1 • 64625 Bensheim
Tel. 06251 / 70585-0 • Fax: 70585-29

Authorized signatory: Michael Glade
Bensheim, 25.11.2021 Qualitätsmanagement

Twin Busch GmbH | Amperestr. 1 | D-64625 Bensheim

twinbusch.de | E-Mail: info@twinbusch.de | Tel.: +49 (0)6251-70585-0



You can find more products at:

twinbusch.co.uk

Twin Busch UK LTD
Kettering
Northants NN16 8PS

Tel.: +44 (0) 1536 522 960
E-Mail: info@twinbusch.co.uk
Web: www.twinbusch.co.uk

The technical specifications and illustrations provided in the user manual are not binding. Our products are subject to technical changes, so the delivered condition may vary.