

# **TW242M**

## **INSTALLATION, OPERATION AND MAINTENANCE MANUAL**



*Always read these operating instructions carefully before operating the lift. Follow the instructions carefully.*

**Table of contents**

- 1. General.....1**
- 2. Identification of the instructions for use .....1**
- 3. Technical data.....1**
- 4. Modification of the product .....1**
- 5. Safety-related information.....1**
  - 5.1 *Safety instructions*.....2
  - 5.2 *Warnings and symbols* .....3
  - 5.3 *Safety devices*.....4
  - 5.4 *Load distribution* .....4
  - 5.5 *Monitoring and testing of the safety equipment*.....5
- 6. Conformity with the product .....5**
- 7. Technical specification .....5**
  - 7.1 *Machine description*.....5
- 8. Structure of lifting platform .....6**
  - 8.1 *Before installation* .....6
  - 8.2 *Ground conditions*.....6
  - 8.3 *Assembly instructions*.....7
  - 8.4 *Test points after assembly*.....13
- 9. Commissioning .....14**
  - 9.1 *Safety precautions*.....14
  - 9.2 *Description of the control unit (control box)*.....14
  - 9.3 *Lifting and lowering sequence plan*.....15
  - 9.4 *Operating instructions*.....16
- 10. Troubleshooting .....17**
- 11. Maintenance .....18**
  - 11.1 *Daily inspection and maintenance of the lifting platform elements before use* .....18
  - 11.2 *Weekly inspection and maintenance of the lifting platform elements* .....18
  - 11.3 *Monthly inspection and maintenance of the lifting platform elements*.....18
  - 11.4 *Annual inspection and maintenance of the lifting platform elements*.....19
- 12. Behavior in the event of an incident .....19**
- 13. Appendix .....20**
  - 13.1 *Lifting platform dimensions*.....20

13.2 Foundation requirement and working area.....21

13.3 Hydraulic system .....24

13.4 Circuit diagrams .....25

13.5 Detailed drawing and parts description of the lifting platform .....28

13.6 Spare parts list .....34

**Further appendix:**

- **EU Declaration of Conformity**

**Important Information:**

**ASSEMBLY**



You can find the assembly video for this lift on YouTube:  
<https://www.youtube.com/watch?v=HJZCN2000aU&t=5s>  
or scan the QR code.



**PRODUCT PRESENTATION**



You can find the product presentation video for this lift on YouTube:  
<https://www.youtube.com/watch?v=30L3xhatnLo>  
or scan the QR code.

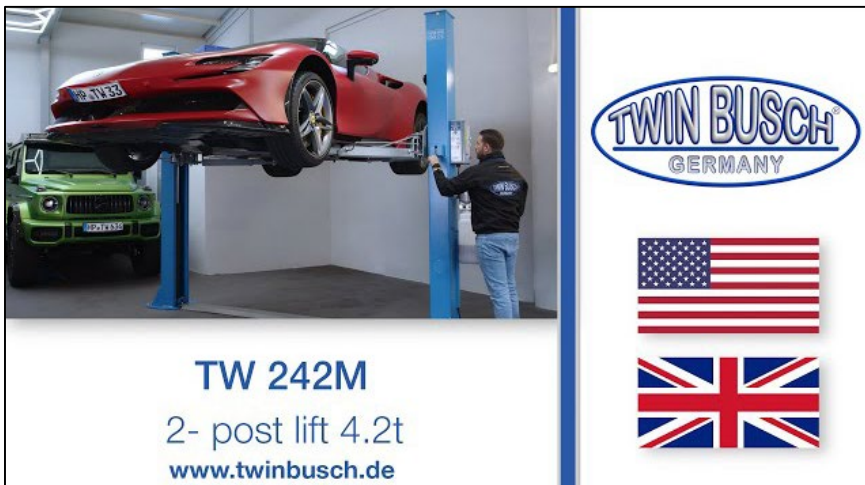



## TIPS & TRICKS



In the "Tips & Tricks" section we show you simple solutions to work even more efficiently with your TWIN BUSCH® products.

<https://www.twinbusch.co.uk/Tips-Tricks: :74.html>

## 24/7 Service Center:



Our **24/7 Self-Service Center** is a mobile website designed for self-diagnosis of issues with your Twin Busch lift. Here, we provide an extensive video collection covering a wide range of relevant topics for your Twin Busch lift, from fine-tuning and maintenance to component replacement.

With the **24/7 Self-Service Center**, you have a versatile tool at your disposal to learn how to independently maintain and repair your Twin Busch lift.

To access the site on your mobile device, please visit [twinbusch.com/qr](https://twinbusch.com/qr) or scan the QR code provided alongside.

For Twin Busch lifts shipped from mid-2020 onwards, you'll also find the QR code on a sticker attached to the control box.

## 1. General

The ideal entry-level model with a TOP price-performance ratio. With height-adjustable turntables and flat ramp plate (only 35 mm). With the BASIC-Line lift, everything from Smart cars to vans can be lifted.

## 2. Identification of the instructions for use

Instruction manual TW 242M

of Twin Busch GmbH,  
Ampèrestraße 1,  
D-64625 Bensheim

Twin Busch UK Ltd.  
9, Linnell Way  
Telford Way Industrial Estate  
NN16 8PS, Kettering (Northants)

Phone: +49 6251-70585-0

Fax: +49 6251-70585-29

Internet: [www.twinbusch.de](http://www.twinbusch.de)

Email: [info@twinbusch.de](mailto:info@twinbusch.de)

Phone: +44 (0) 1536 522 960

Internet: [www.twinbusch.co.uk](http://www.twinbusch.co.uk)

Email: [info@twinbusch.co.uk](mailto:info@twinbusch.co.uk)

Version: -01, 10.04.2024

File: TW242M\_2-Post-Lifts\_Manual\_uk\_01\_20240410

## 3. Technical data

Power supply (3-phase)	230 V / 50 Hz
Fuse protection	C 16A (sluggish response)
Load capacity	4,200 kg
Degree of protection	IP 54
Lifting time	approx. 45 sec
Lowering time	approx. 30 sec
Net weight	580 kg
Noise level	< 70 db
Working environment	Working temperature: -15°C to +40°C
	rel. Humidity: 30% to 85 %

## 4. Modification of the product

Improper use, as well as modifications, conversions and attachments of the lift and all its components not agreed with the manufacturer are not permitted. The manufacturer will not accept any liability in the event of improper installation, operation or overloading. Likewise, improper use will invalidate the CE certification and the validity of the expert opinion.

If there are any modification requests, please contact your dealer or the expert personnel of the Twin Busch GmbH beforehand.

## 5. Safety-related information

Read the instruction manual carefully before operating the lift. Keep the instructions for reference. Follow the instructions carefully to obtain the best performance from the machine and to avoid damage due to personal fault. Unpack all parts and check with the help of the packing list whether all components are present. Check all connections and components thoroughly for damage. The lifting platform may only be put into operation if it is in a safe operating condition.

## 5.1 Safety instructions

- Do not install the lift on an asphalt surface.
- Read and understand the safety instructions before operating the lift.
- Do not under any circumstances leave the control panel when the lift is in motion.
- Keep your hands and feet away from moving parts. Pay particular attention to your feet when lowering.
- The lifting platform is to be operated by trained personnel only.
- Uninvolved persons are not allowed near the lifting platform.
- Wear suitable work clothing.
- The area around the lifting platform should always be kept free of obstructing objects.
- The lift is designed for lifting motor vehicles that do not exceed the maximum permissible weight.
- Always ensure that all safety precautions are taken before working near or under the vehicle.

**Never remove safety-relevant components from the lifting platform. Do not use the lifting platform if safety-relevant components are missing or damaged.**

- Do not under any circumstances move the vehicle or remove heavy objects from the vehicle that could cause significant weight differences while the vehicle is on the lift.
- Always check the mobility of the lift to guarantee its performance. Ensure regular maintenance. If any irregularity occurs, stop working with the lift immediately and contact your dealer.
- Lower the lift completely when not in use. Do not forget to disconnect the power supply.
- If you do not use the lift for a longer period of time, then:
  - a. Disconnect the lift from the power source.
  - b. Empty the oil tank.
  - c. Lubricate the moving parts with lubricating oil/grease.

**Caution: To protect the environment, dispose of the oil that is no longer used in the prescribed manner.**

- For safe lifting of transporters, it is essential to use the optional special lifting adapters.  
You can find these at: [www.twinbusch.co.uk](http://www.twinbusch.co.uk)

**5.2 Warnings and symbols**

All warning labels are clearly visible on the lift to ensure that the user uses the equipment in a safe and appropriate manner.

The warning signs must be kept clean and replaced if they are damaged or missing. Please read the signs carefully and memorise their meaning for future operations.

	Before use Instructions and safety instructions read carefully!		Operation of the lifting platform only by qualified personnel!
	Repairs and maintenance only by qualified personnel, never put safety devices out of operation!		Only qualified personnel allowed in the vicinity of the lifting platform!
	Escape routes always keep clear!		It is forbidden for persons to stand under the lifting platform (when lifting or lowering)!
	Watch your feet when lowering! Danger of crushing!		Climbing on the lifting platform is strictly prohibited!
	Observe the vehicle manufacturer's mounting points!		After lifting the vehicle for a short time, check that it is securely seated!
	Do not exceed the specified load capacity!		When installing and removing heavy parts the vehicle can tip over!
	Never try to load only one side of the lifting platform!		Protect the lifting platform from moisture! Electrical connections must be dry!
	Avoid strong shaking. Avoid shaking the vehicle.		CAUTION! Electrical voltage!



### 5.3 Safety devices

For safe operation of the lifting platform, it is equipped with the following safety devices \*):

- Safety detents
- Throttle valve in hydraulic line
- Limit switch
- Carrying arm locking device
- Devices against jamming and crushing (shaft protection, foot deflector)
- Synchronisation lines

*\*) depending on the design and type of the lifting platform*

### 5.4 Load distribution

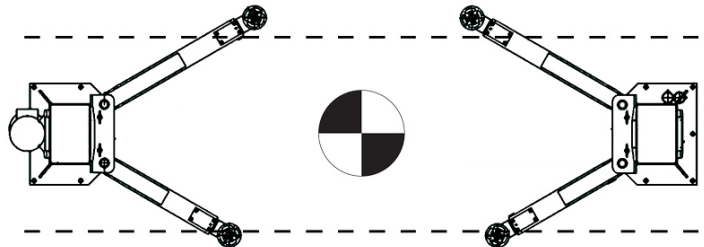
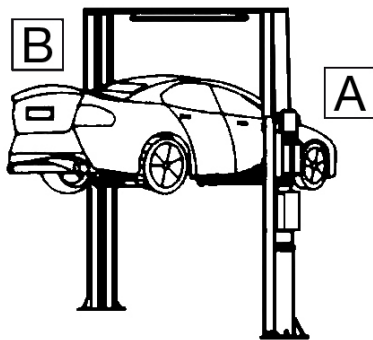

Lifting Capacity	Load distribution	
	B	A
3.6 T	1.5 T	2.1 T
4.2 T	1.9 T	2.3 T
5.0 T	2.5 T	2.5 T
6.0 T	3.0 T	3.0 T

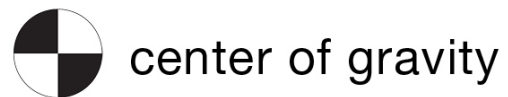

## 5.5 Monitoring and testing of the safety equipment

- |                           |   |
|---------------------------|---|
| - Safety catch            | Function test, when lowering the lift, safety catches must engage simultaneously and stop the downward movement.                  |
| - Throttle valve          | Fixed throttle, checking by user not possible   |
| - Limit switch            | When the limit switch is pressed, the motor stops or cannot start.  |
| - Support arm lock        | When the support arms are raised, the support arm lock must engage and remain securely locked in place when loaded from the side. |
| - Devices against jamming | Must be in place, in working order and must not be deformed or damaged.   |
| - Synchronisation cable   | Check steel cables regularly.   |

## 6. Conformity with the product

The 2-post lift TW242M is CE-certified and is compliant with the Machinery Directive 2006/42/EC, fulfilling the standards EN 1493:2022, EN 60204-1:2018 (look at: EU Declaration of Conformity, at the end of the user manual).

## 7. Technical specification

### 7.1 Machine description

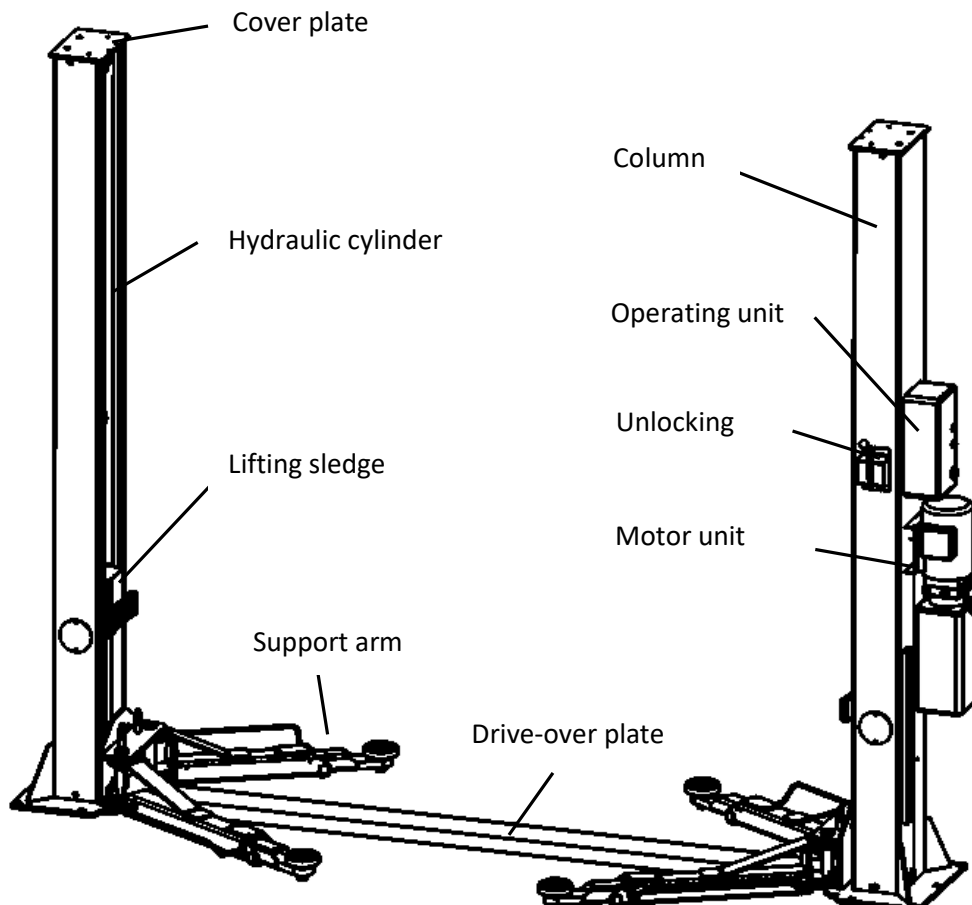

## **8. Structure of lifting platform**

### **8.1 Before installation**

Tools and equipment needed:

- Suitable lifting tool for the bulky and heavy components
- Hammer, pliers
- Phillips and slotted screwdriver
- Set of Allen spanners
- Spanner attachments and open-end spanners
- Impact drill
- Hydraulic oil HLP 32

### **8.2 Ground conditions**

The lifting platform must be installed on a solid foundation with a compressive strength of more than 3 kg/mm<sup>2</sup>, a flatness of less than 5 mm and a minimum thickness of 200 mm. Detailed information can also be found in the corresponding foundation plan on our homepage at [www.twinbusch.co.uk](http://www.twinbusch.co.uk).

Note: If a new concrete floor is to be poured, it must rest for at least 28 days until a lifting platform can be installed.

### 8.3 Assembly instructions

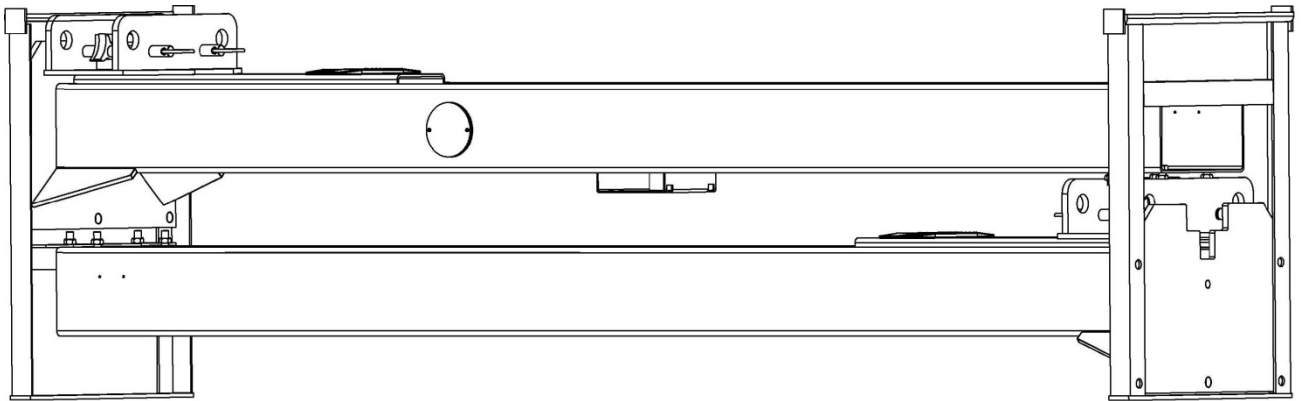

- 1) Remove the packaging and take out the box with the accessories and cover plates. Read and understand the operating instructions before proceeding.
- 2) First you have to put a support between both columns or lift one of the columns with the help of a lifting tool. Then remove the upper screws from the frame.

**Attention: Please take special care that the column cannot fall down. The accessories could be damaged or people could be injured.**

- 3) After removing the first column, place a support under the lower column. Then remove these screws from the transport frame.
- 4) Set up both columns. Align the main and secondary columns with each other (outer edge of base plate to outer edge of base plate approx. 3436 mm).
  - a) After unpacking, you must decide where you want to place the column with the power supply, the control unit and the release.
  - b) Set up one column, place the drive-over plate against this column and determine the exact distance by setting up the second column and placing it against the second side of the drive-over plate.
- 5) First attach the main column, then the secondary column.
  - a) Drill the holes in the foundation for each ground anchor using a percussion drill. Drill perpendicular to the ground level.
  - b) Remove dirt and dust carefully after drilling (vacuum and blow out if necessary).

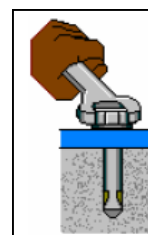
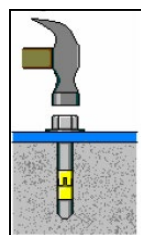
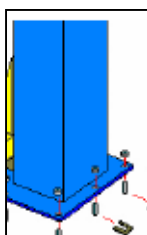
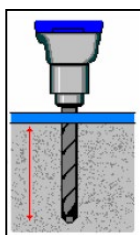

- 6) Assemble the hydraulic system
  - a) Mount the motor unit

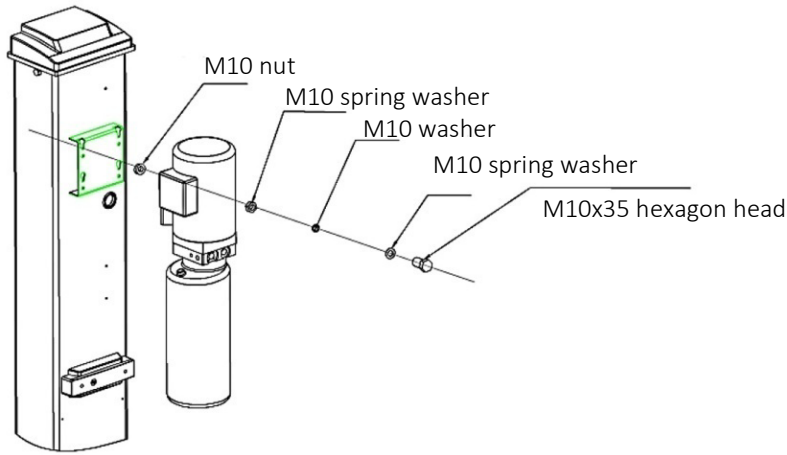

- b) Make sure that all hose ends are clean and free of dirt.
- c) Connect the hydraulic lines as shown in the following illustration or in the hydraulic circuit diagram.

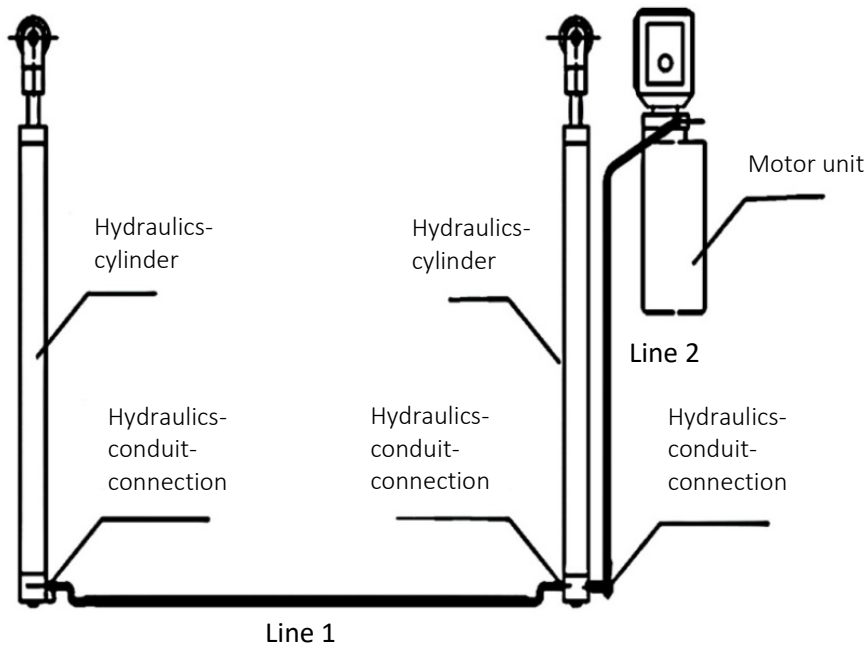

7) Lay and fasten the release steel cable according to the following illustration

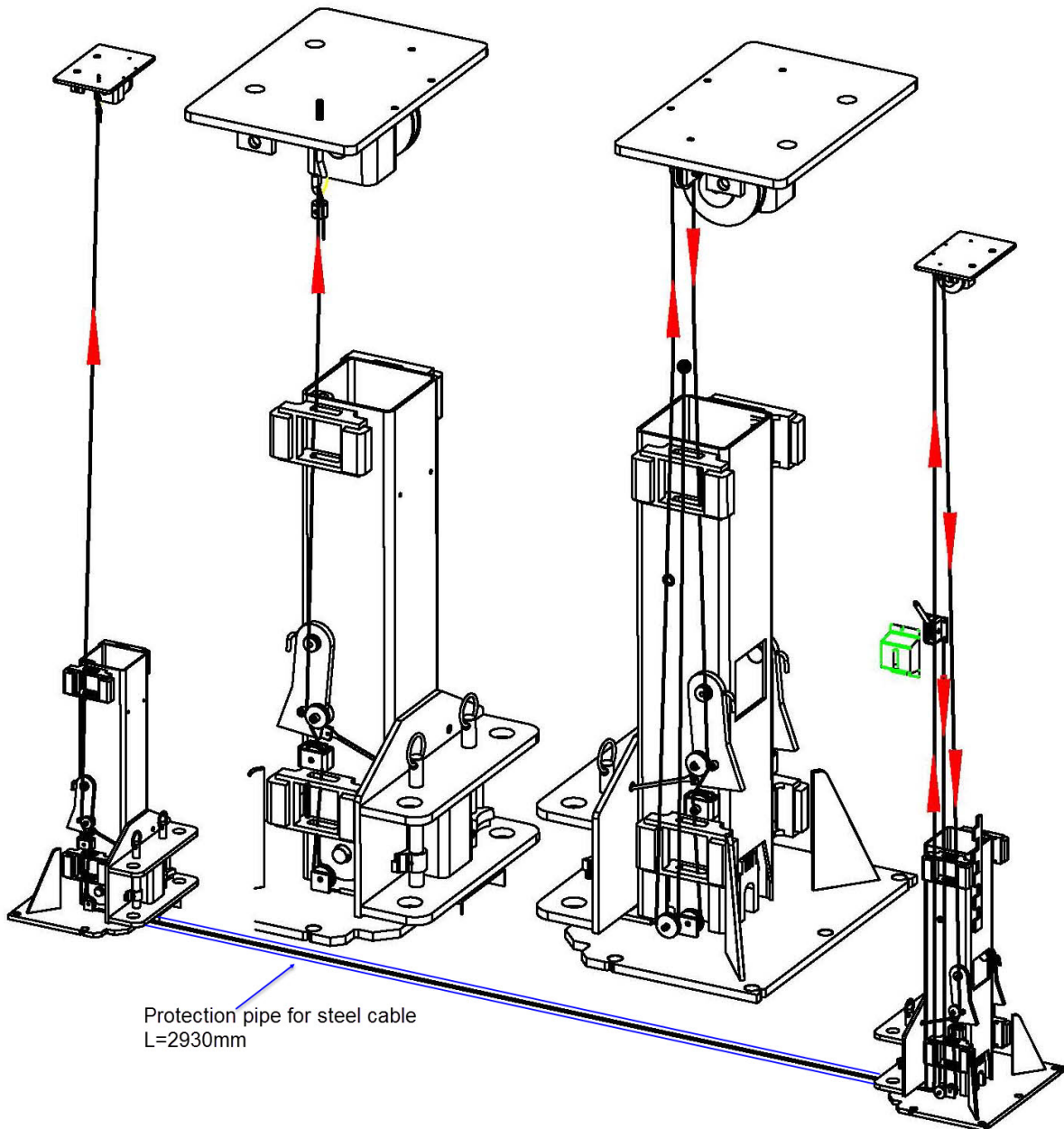

8) Connect the slides to the steel cable

- a) Align the carriages on both sides of the column approx. 800 mm above floor level.
- b) Make sure that the safety catches on both sides of the column are engaged before you start installing the steel cables.
- c) **The carriages must be level with the ground before proceeding.**
- d) Pull in the steel cables as shown in the following illustration.
- e) The steel cables must be set "tight" on both sides of the column. Make sure that during a later test run the safety catches on both sides can be heard synchronously. If this is not the case, the steel cables or a steel cable must be retightened.
- f) The ropes must always be secured against unintentional loosening (locken off) and oiled with WD40 to ensure a long service life.

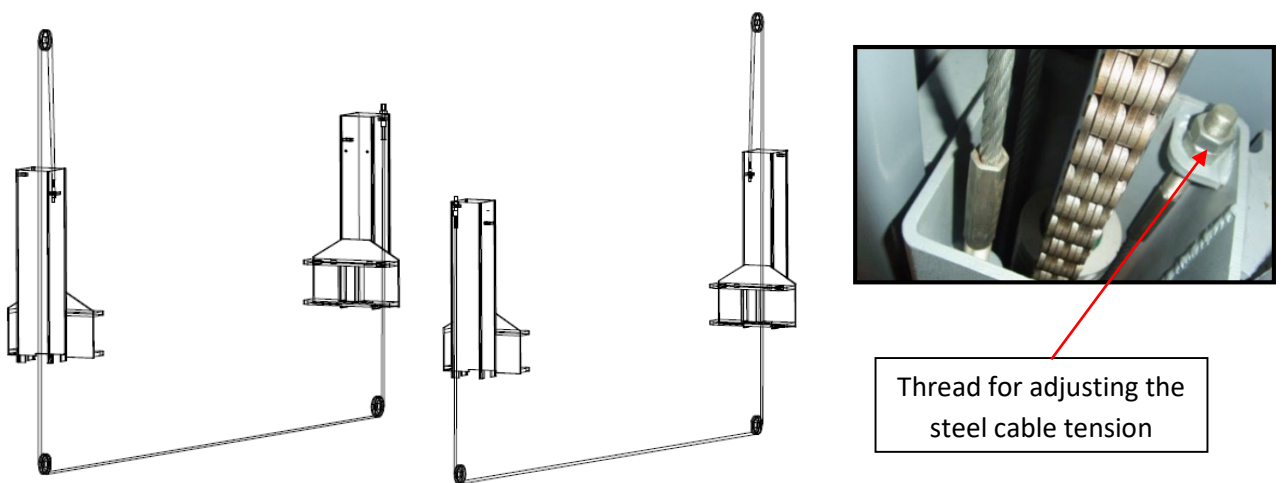

Thread for adjusting the steel cable tension

**Caution: After adjusting the steel cable tension, the adjusting nuts on both sides of the column must be locked with another nut!**

9) Mount the operating control unit on the control box

- a) Mount the control unit on the main column.
- b) Connect the power supply to the control unit as shown in the following figure.

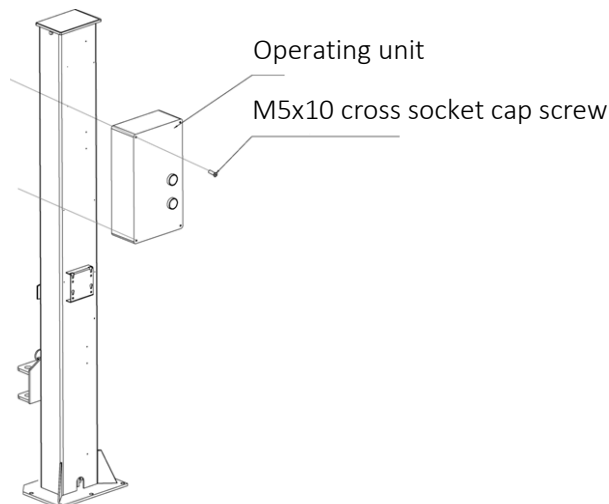

c) Mount the limit switch at the top of the main column as shown in the following figure.

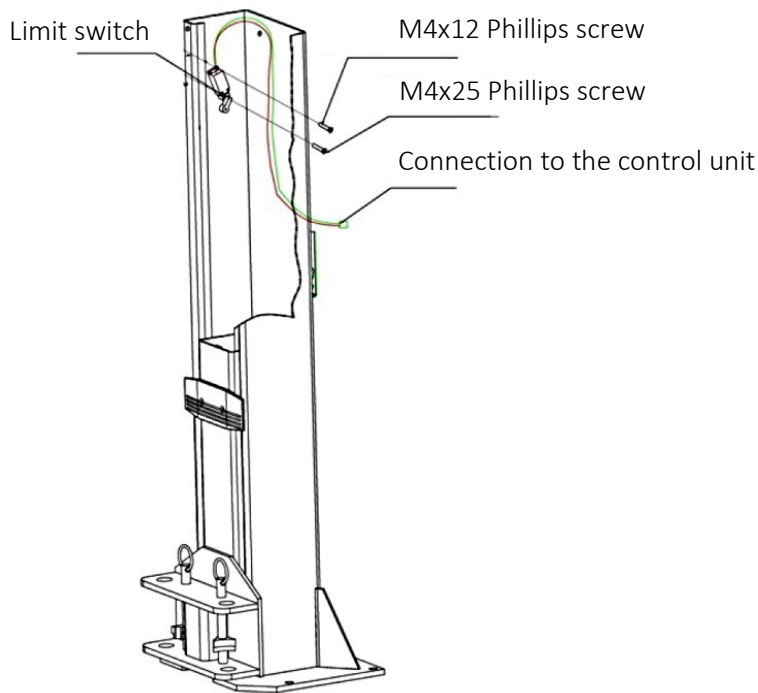

10) Mount the support arms

- a) Insert the support arms into the lifting slides, pay attention to the interlocking of the anti-rotation blocks.
- b) Place the support arm bolts in the holes provided, as shown in the following figure.

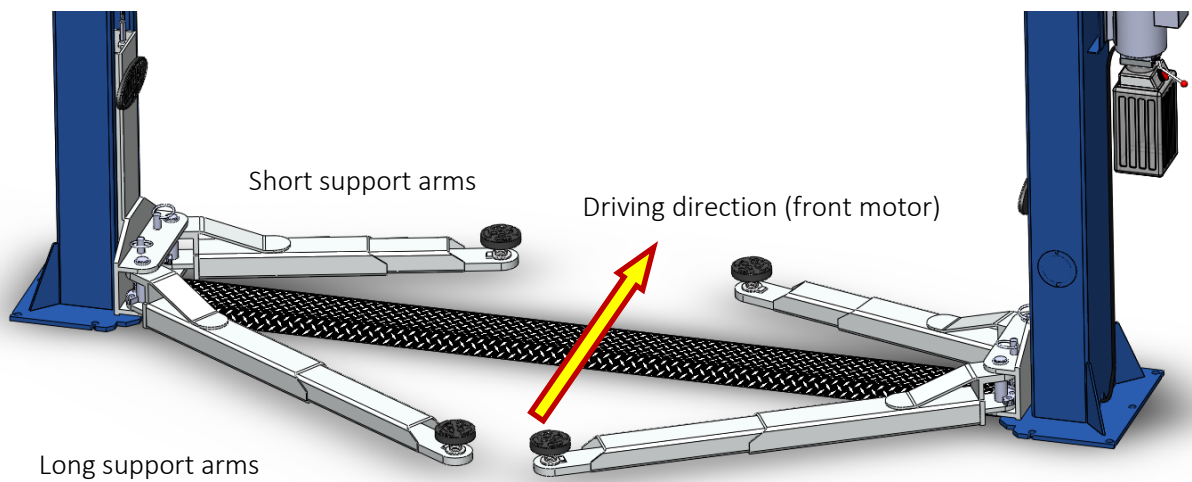



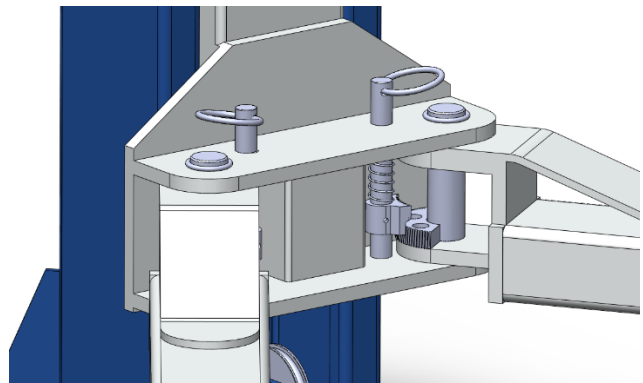
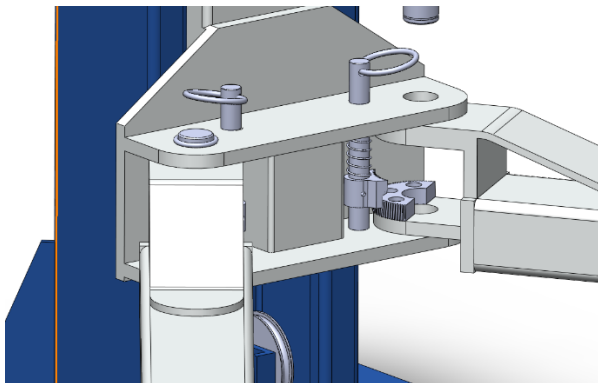
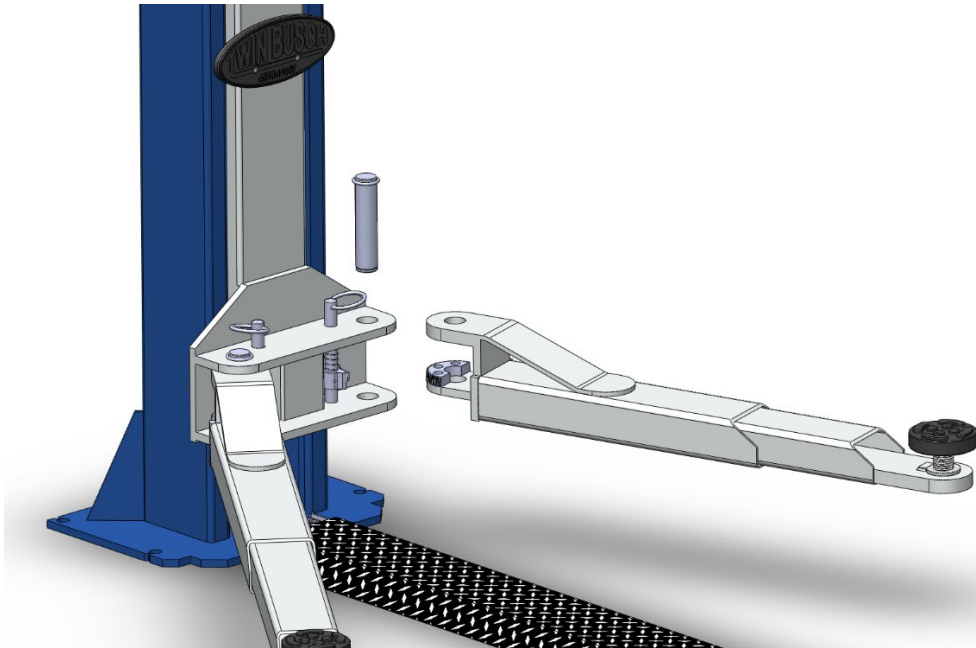

Insert the support arm, lifting the support arm rotation lock. Insert bolt, secure with circlip.

### 11) Filling the hydraulic system

The hydraulic oil tank has a capacity of approx. 10 liters. To ensure that the lift functions correctly, you should fill the oil tank to 80 % with hydraulic oil. **Hydraulic oil type: HLP 32**

### 12) Test run

- a) Follow the procedure in paragraph **9 Commissioning** and make absolutely sure that NO vehicle is on the lifting platform during a test run.
- b) Before the test run, check all connections and terminals for correct functioning.

13) Fit the door stop guard



14) Fit the ramp plate

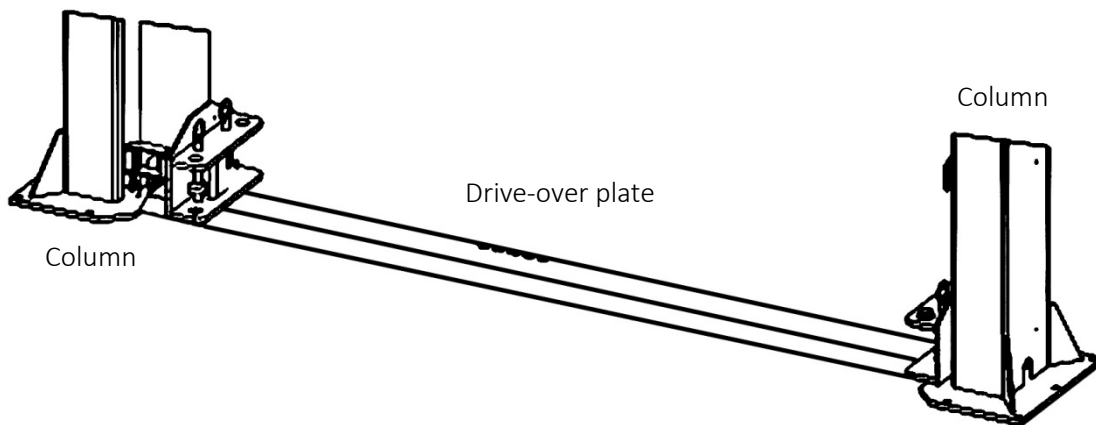

#### 8.4 Test points after assembly

S/N	Check	YES	NO
1	Are the columns vertical to the floor? (90°)		
2	Are the two columns parallel to each other?		
3	Is the oil hose connected correctly?		
4	Is the steel cable correctly and firmly connected?		
5	Are all support arms correctly and firmly mounted?		
6	Are the electrical connections correct?		
7	Are the joints all screwed tight?		
8	Are all parts that need greasing greased?		

## 9. Commissioning

### 9.1 Safety precautions

- a) If the safety devices are defective or show any abnormalities, the lifting platform must not be operated under any circumstances!
- b) Check all connections of the hydraulic lines for tight fit and proper functioning. If there are no leaks, a lifting operation can be started.
- c) Only the operator should be near the lift during a lifting or lowering operation. Always ensure that there are no persons in the danger zone.
- d) Vehicles should always be aligned so that the vehicle's center of gravity is centrally located between the lift columns. If this is not the case, the lift should not be used. Otherwise, neither we nor the intermediary dealer, if any, will accept responsibility for any problems or damage caused as a result.
- e) When the desired lifting height has been reached and the safety catches are engaged, switch off the power supply to the lifting platform before starting work in order to avoid incidents caused by unintentional operation by other persons.
- f) Make sure that the safety catches are engaged before starting work on or under a vehicle. No persons should be in the working area of the lift during the lifting and lowering process.

### 9.2 Description of the control unit (control box)

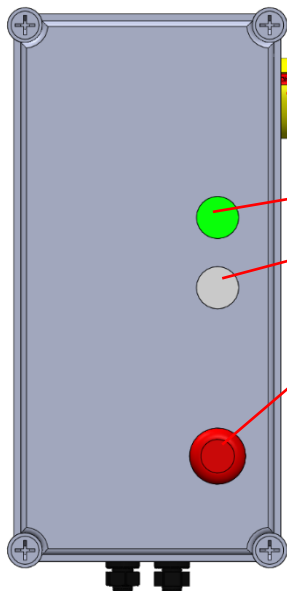

Description	Function
Main switch	Switch on or off
Operating light	Indicates whether there is power
UP button (push-button)	Lifting the lifting platform
Emergency stop switch	Switches the system off in an emergency

### 9.3 Lifting and lowering sequence plan

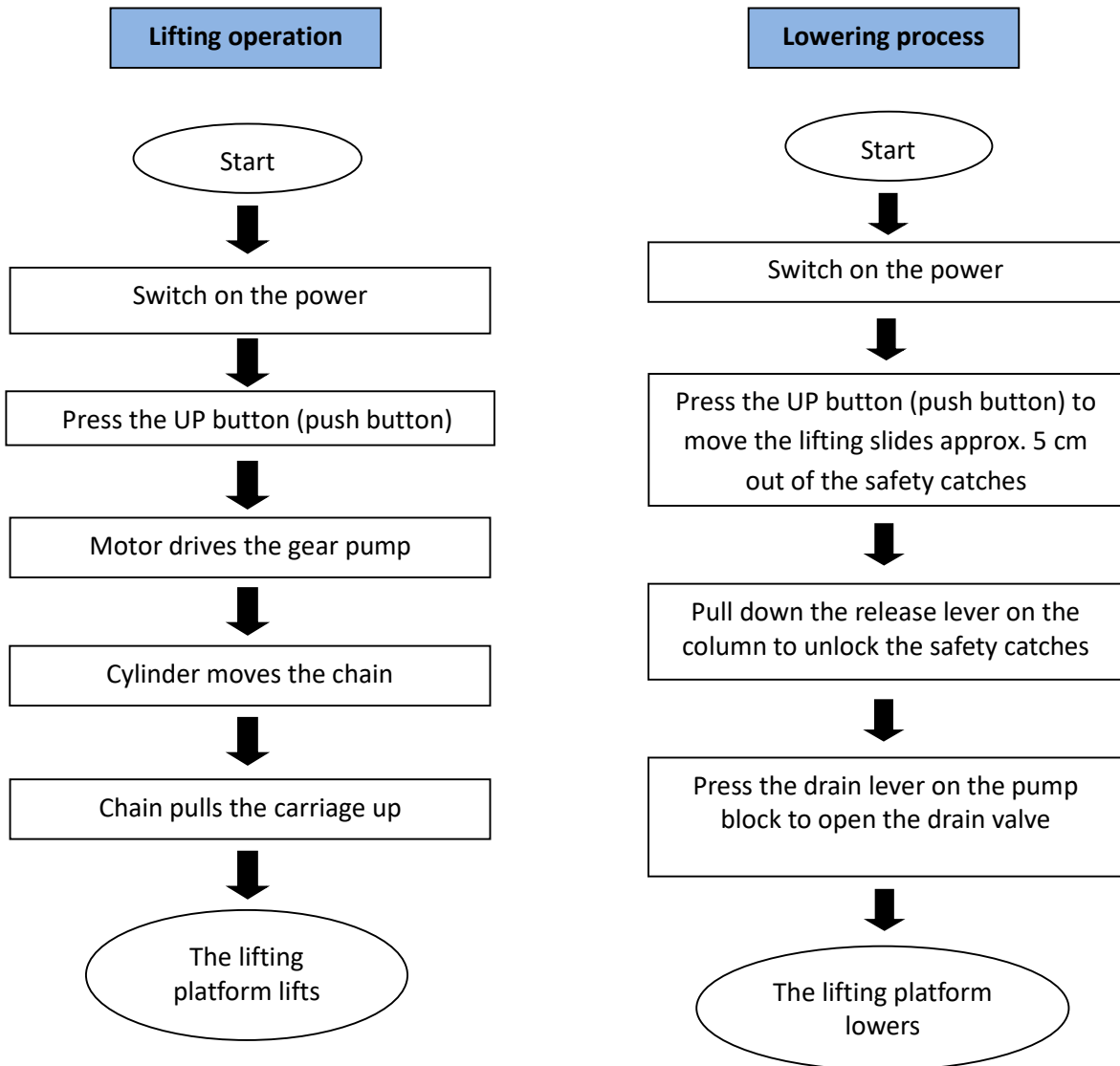

## **9.4 Operating instructions**

### **9.4.1 Lifting operation**

1. **Read and understand the operating instructions before starting work.**
2. Connect the power supply and turn the main switch to ON.
3. Park the vehicle with the vehicle's center of gravity centered between the two pillars.
4. Align the lift's support arms so that the vehicle's pick-up points are aligned with the lift's pick-up points. Make sure that the vehicle is positioned correctly.
5. Switch on the lift and press the UP button (push button) on the control unit until the pick-up of the support arms touches the vehicle at the pick-up points specified by the vehicle manufacturer and the vehicle has lifted about 10-15 cm. Stop the lifting process and make sure that the vehicle has been picked up correctly and safely.
6. After final alignment and check, press the UP button again and keep it pressed until the desired lifting height is reached.
7. Press the release lever to lower the lift slides into the safety catches.
8. Turn the main switch to OFF and start working on or under the vehicle.

### **9.4.2 Lowering process**

1. Connect the power supply and turn the main switch to ON.
2. Press the UP button (push button) to move the lifting slides approx. 5cm out of the safety catches.
3. Pull and hold the release lever on the column downwards to unlock the safety catches.
4. Press the drain lever on the pump block to open the drain valve.
5. As soon as the lifting carriages have reached the lowest position, the support arms can be swung out from under the vehicle.
6. Now the vehicle can be removed.

## 10. Troubleshooting

**Attention:** Do not hesitate to contact the expert staff of Twin Busch GmbH if you are unable to rectify an error yourself. We will be happy to assist you in rectifying the problem. In this case, document the error and send us pictures and a precise description of the error so that we can identify and remedy the cause as quickly as possible.

The following table lists possible errors, their cause and the corresponding troubleshooting for quicker identification and self-remedy.

PROBLEMS	CAUSE	SOLUTION
Unusual noise.	Wear on the inner side of the columns.	Grease the inside of the columns.
	Pollution in the columns.	Remove the dirt.
Motor will not start, nor will the lift go up.	The cable connections are loose.	Check the cables and reconnect them.
	The motor is defective.	Replace it.
	The limit switch is defective/damaged or the cable connection is loose.	Reconnect the cables or replace the limit switch.
Motor runs but does not raise the lift.	The motor runs backwards/ in the wrong direction of rotation.	Check the cable connection.
	The pressure relief valve is loose or dirty.	Clean or screw it tight.
	The gear pump is defective.	Replace them.
	The oil level is too low.	Top up with oil.
	The oil hose has come loose or is torn off.	Fix or replace it.
	The damping valve is loose or pinched/clogged.	Clean or fix it.
The beams descend slowly after they have been raised.	The oil hose is leaking.	Check or replace it.
	The oil cylinder/piston is leaking.	Replace the gasket.
	The directional valve is leaking.	Clean or replace it.
	The pressure relief valve is leaking.	Clean or replace it.
	Manual or electric drain valve is leaking/dirty.	Clean or replace it.
Lifting too slowly.	The oil filter is dirty or jammed.	Clean or replace it.
	Oil level is too low.	Top up with oil.
	The overpressure valve is mounted incorrectly.	Mount it correctly.
	The hydraulic oil is too hot. (over 45°C)	Change the oil.
	The seal of the cylinder is worn.	Replace the gasket.
Lowering too slowly.	The throttle valve is jammed/dirty.	Clean or replace it.
	The hydraulic oil is dirty.	Change the oil.
	The drain valve is blocked.	Clean it.
	The oil hose is damaged/kinked.	Replace it.
The steel cable is worn out.	Not greased during installation or it is worn out.	Replace it.

## 11. Maintenance

Regular maintenance of your lift will ensure a long and safe use of the lift. The following are suggestions for the maintenance intervals and the activities to be carried out. How often you service your lift depends on the environmental conditions, the degree of contamination and, of course, the stress and load on the lift.

The following points must be lubricated:

S/N	Description
1	Upper pulley
2	Steel cable
3	Sprocket
4	Chain
5	Sledge
6	Bolt
7	Safety block
8	Support arm
9	Screw threads
10	Lower pulley

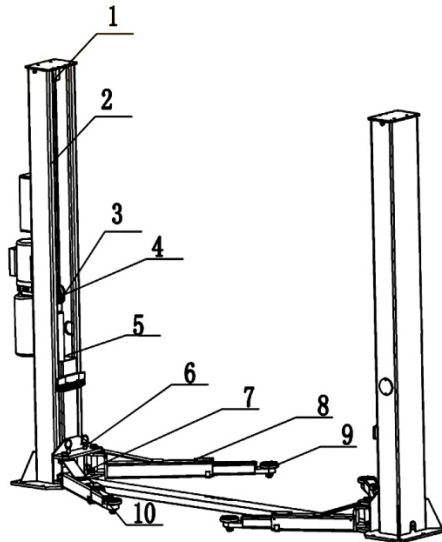

### 11.1 Daily inspection and maintenance of the lifting platform elements before use

A daily check of the safety-relevant components must be carried out before each commissioning! This can save you a lot of time due to a failure, major damage or even injuries.

- Check all connections and screw connections for tightness.
- Check the hydraulic system for leaks and functionality.
- Check the support arm locks for correct operation.
- Check in a test run (without vehicle) whether the safety catches function properly.
- Clean heavily soiled lifting platform elements.
- Lubricate all lifting platform elements that are not well lubricated.

### 11.2 Weekly inspection and maintenance of the lifting platform elements

- Check the mobility of all adjustable and flexible lifting platform elements.
- Check the condition and correct functioning of all safety-relevant lifting platform elements.
- Check the level of the hydraulic oil (lowered lift carriage - level high, max. raised lift carriage - level low).

### 11.3 Monthly inspection and maintenance of the lifting platform elements

- Check all screw connections and joints for tightness.
- Check the lifting carriage, the support arm bolts, the support arms and all other moving lifting platform elements for wear and lubricate them.
- Check the condition of the steel cable for signs of wear and oil the steel cable with thin lubricating oil.

### 11.4 Annual inspection and maintenance of the lifting platform elements

- Empty and clean the hydraulic oil tank and renew the hydraulic oil.
- Replace the oil filter.

If you follow the above maintenance intervals and maintenance activities, your lift will remain in good condition and damage and accidents will continue to be avoided.

## 12. Behavior in the event of an incident

If the lift malfunctions, simple faults may be the cause. Use the following list for troubleshooting \*).

If the cause of the error is not listed or cannot be found, please contact the expert Twin Busch GmbH team.

*Never attempt to carry out repairs yourself, especially on safety devices or electrical system parts.*

\*) Points depending on the design and type of the lifting platform





Work on electrical systems only by qualified electricians!

**Problem: Lifting platform can neither be raised nor lowered.**

Possible causes

- No power supply available.
- Power supply interrupted.
- Main switch not switched on or defective.
- Emergency stop pressed or defective.
- Fuse in power connection has blown or is defective.
- Fuse in the switch box has blown or is defective.

Remedy



- Check power supply.
- Check power supply line.
- Check main switch. 
- Unlock emergency stop, check. 
- Check fuse.
- Check fuse.

**Problem: Lifting platform cannot be raised.**

Possible causes

- With three-phase current: one phase is missing.
- With three-phase current: Direction of rotation of motor reversed.
- Oil pump defective.
- Emergency drain open.
- Motor is defective.
- Overload.

Remedy

- Check power supply. 
- Check direction of rotation, change phase if necessary. 
- Notify Twin Busch Service.
- Close emergency release valve.
- Notify Twin Busch Service.
- Overload valve has opened, reduce load.

**Problem: Lift cannot be lowered.**

Possible causes

- Lifting platform sits in safety catches.
- Lifting platform has moved into limit switch.
  
- Motor is defective.
  
- Lifting platform has been blocked during lowering.

Remedy

- Raise platform a little, pull detents, lower.
- If necessary, loosen limit switch, raise 1 cm and lower.
- Open safety latch and lift over.
- Lower emergency drain.
- Raise the lifting platform slightly again and remove the obstacle.



### 13. Appendix

#### 13.1 Lifting platform dimensions

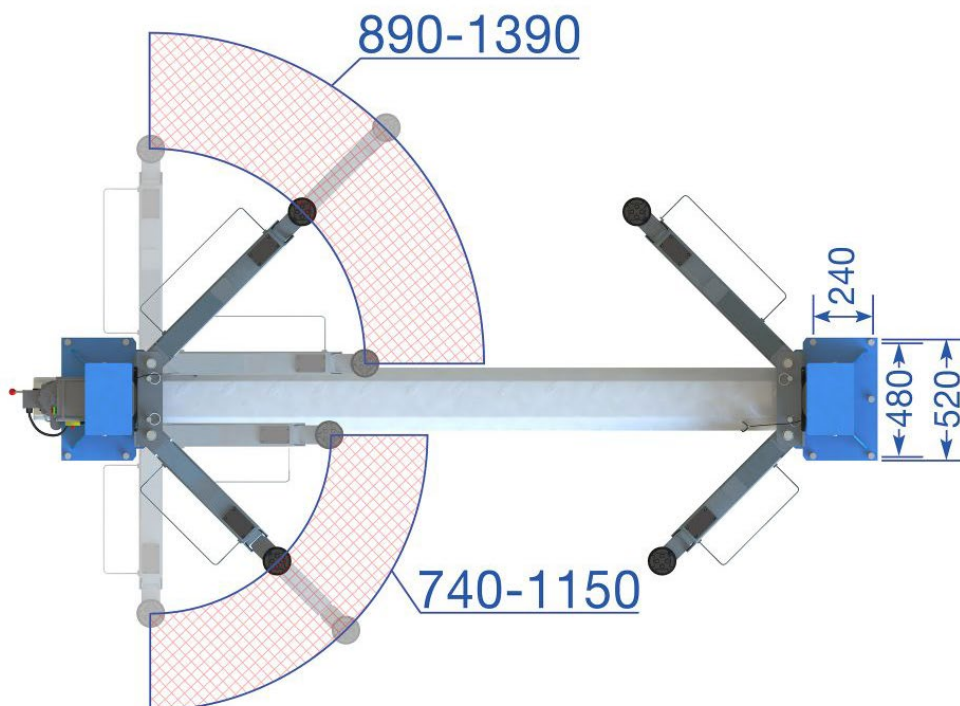
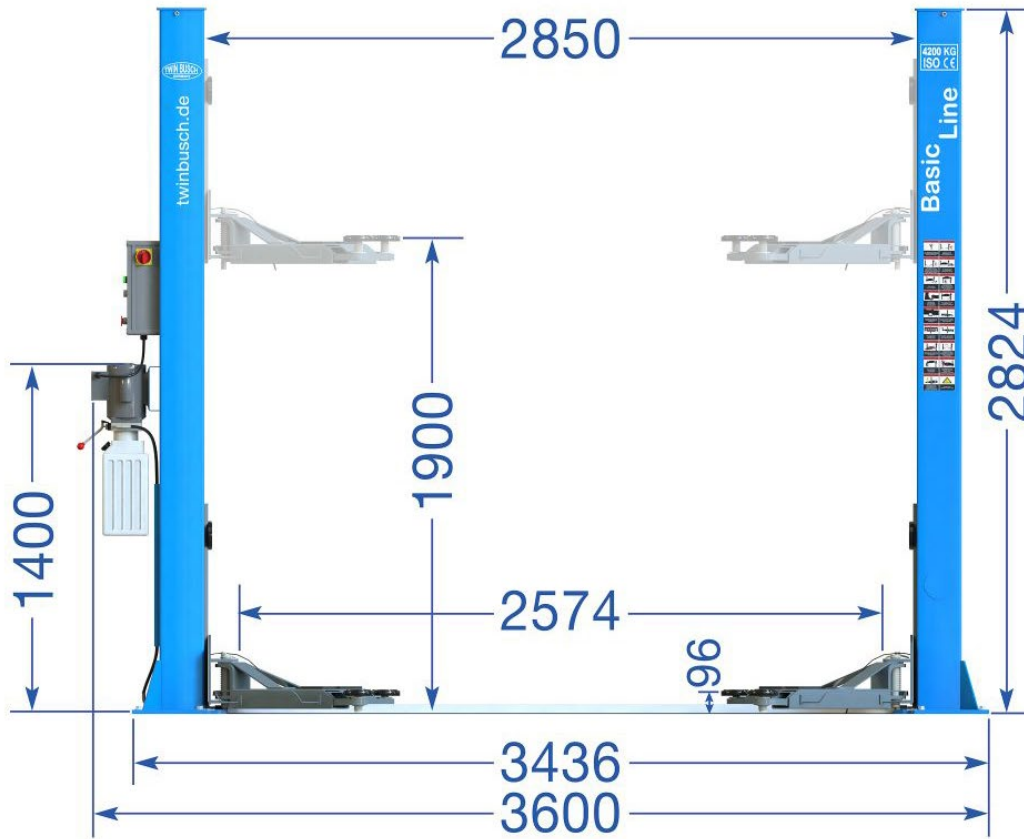

### 13.2 Foundation requirement and working area

#### Requirements for the concrete:

- Concrete C20/25 according to DIN 1045-2 (Previous designation: DIN 1045 Concrete B25).
- Floor must be horizontal and evenness less than 5 mm/m.
- Newly poured concrete must cure for at least 28 days.

#### Foundation dimensions:

- Ideally, the entire hall floor should be made of concrete C20/25 with a thickness of at least 200 mm.

Minimum dimensions of the foundation plate (lifting platform placed centrally):

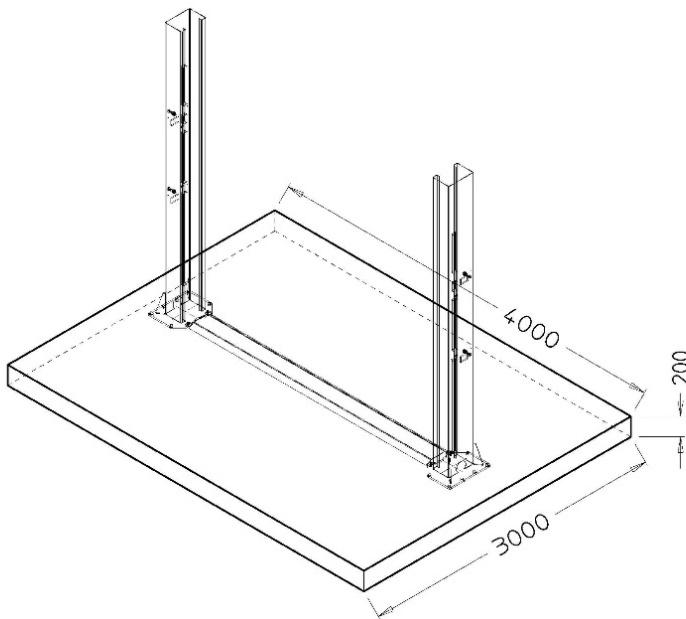

#### Alternatively, in H-shape or two blocks:

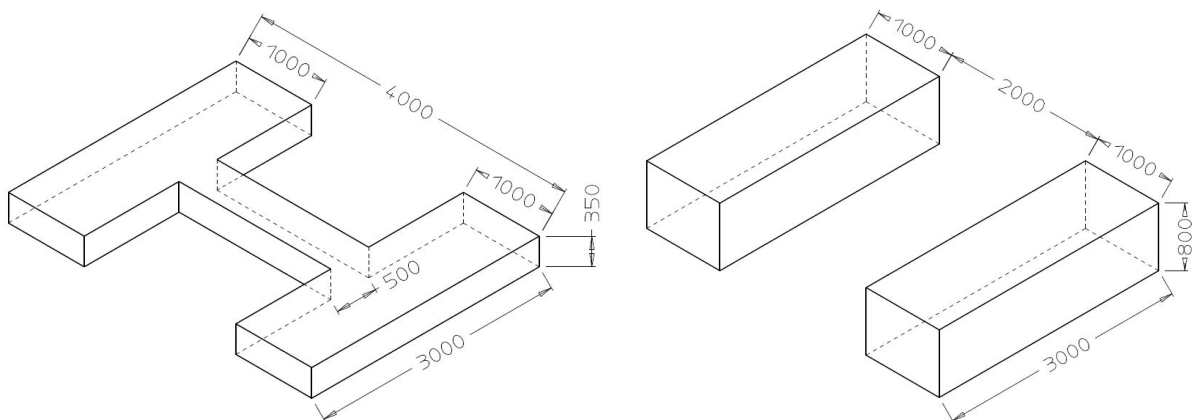

## Other requirements:

- The surrounding soil must be suitable for the load, e.g. no sandy soils, etc.
- Reinforcements in the concrete are not mandatory for proper use of the lifting platform, but are recommended.
- In case of doubt, the foundation should be determined and checked by a structural engineer.

## For soil exposed to frost, note the following:

For frost exposure, the concrete must comply with exposure class XF4, as dripping de-icing agent cannot be ruled out.

This results in the following minimum requirements for the concrete when exposed to frost:

Exposure class:	XF4
Maximum w/c:	0,45
Minimum compressive strength:	C30/37 (instead of C20/25)
Minimum cement content:	340 kg/m <sup>3</sup>
Minimum air void content:	4.0 %

It must be noted, however, that the lifts are not designed for outdoor use. The control box is IP54, but the rest of the electrics, motors and limit switches are IP44 at most.

## Anchor bolt fastening

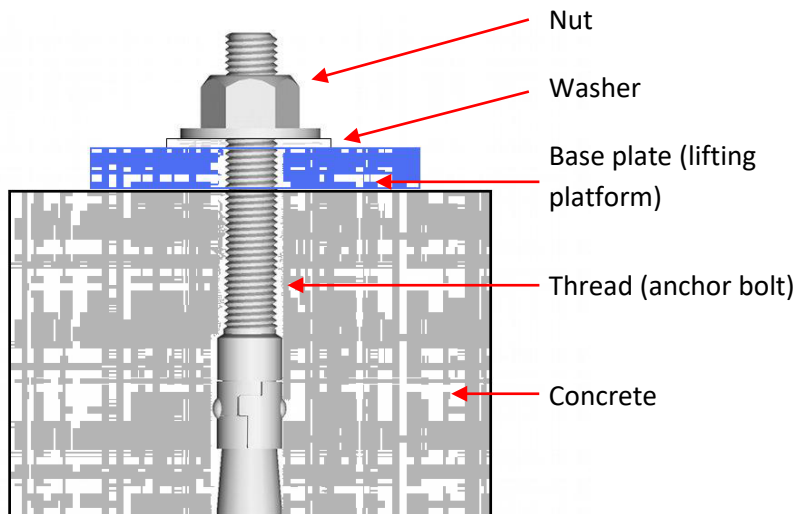

**Tightening torque of the anchor bolts  
is: 110 Nm (for M16)**

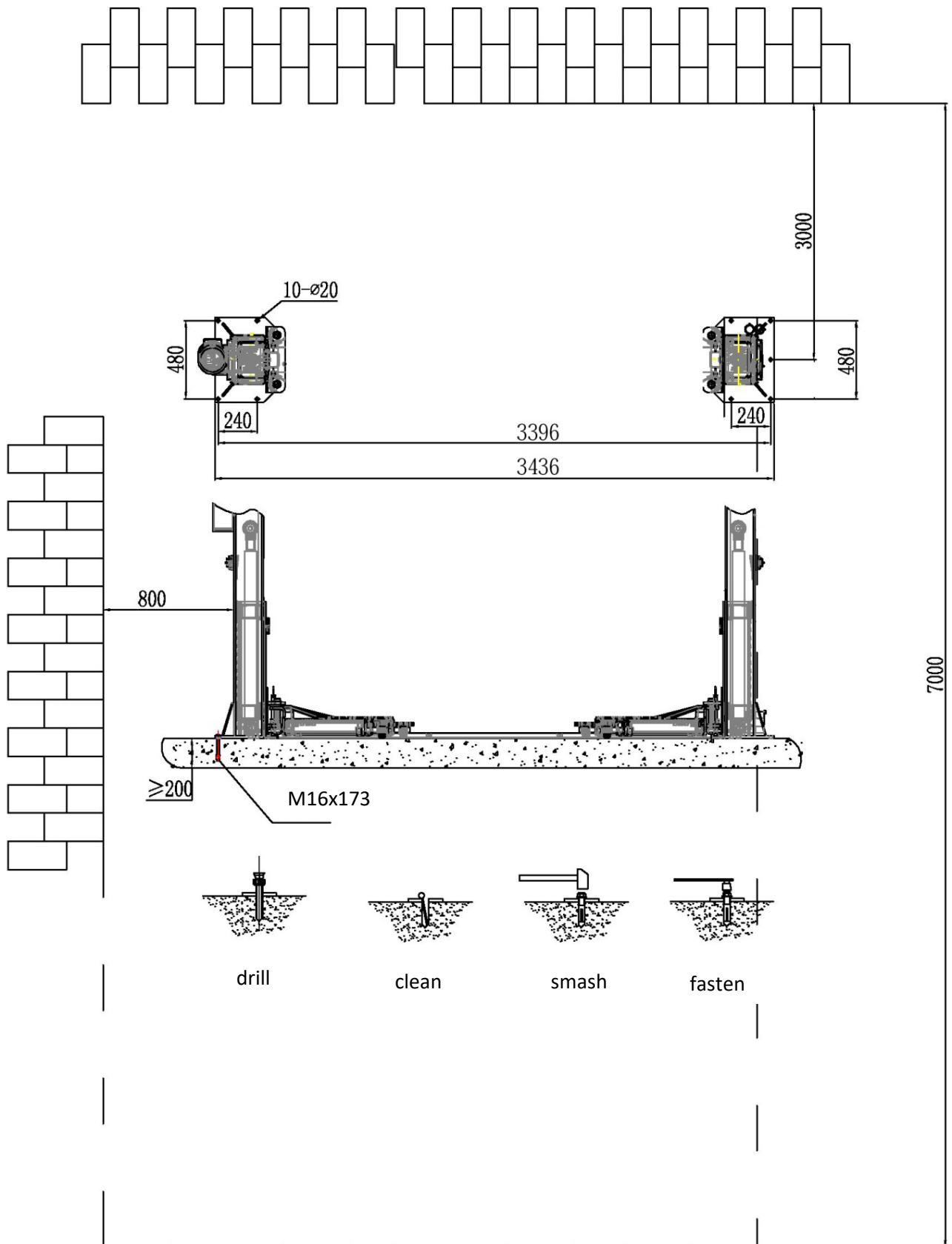

13.3 Hydraulic system

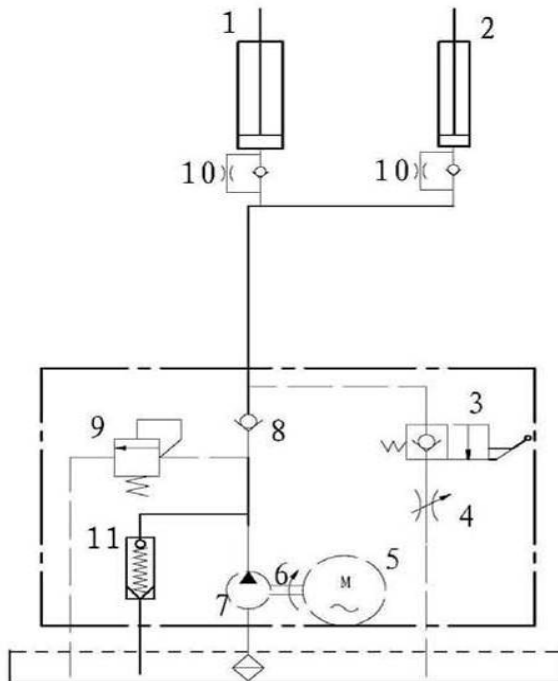

1. Master cylinder
2. Secondary cylinder
3. Manual drain valve
4. Throttle valve
5. Motor
6. Coupling
7. Gear pump
8. Check valve (one-way valve)
9. Pressure relief valve (max.: 19.4 Mpa)
10. Throttle check valve
11. Pressure regulating valve

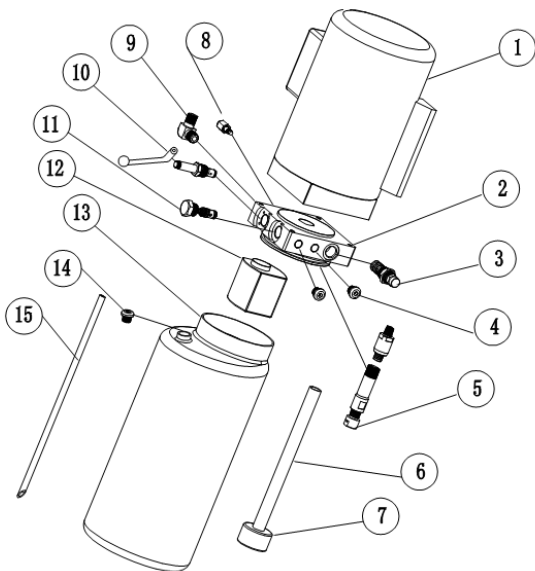

S/N	Name	Number
1	Motor	1
2	Hydraulic block	1
3	Pressure relief valve	1
4	Screw plug	2
5	Pressure regulating valve	1
6	Oil suction pipe	1
7	Oil filter	1
8	Throttle valve	1
9	Connection	1
10	Electromagn. drain valve	1
11	One-way valve	1
12	Gear pump	1
13	Plastic oil tank	1
14	Oil tank plug	1
15	Oil return line	1

13.4 Circuit diagrams

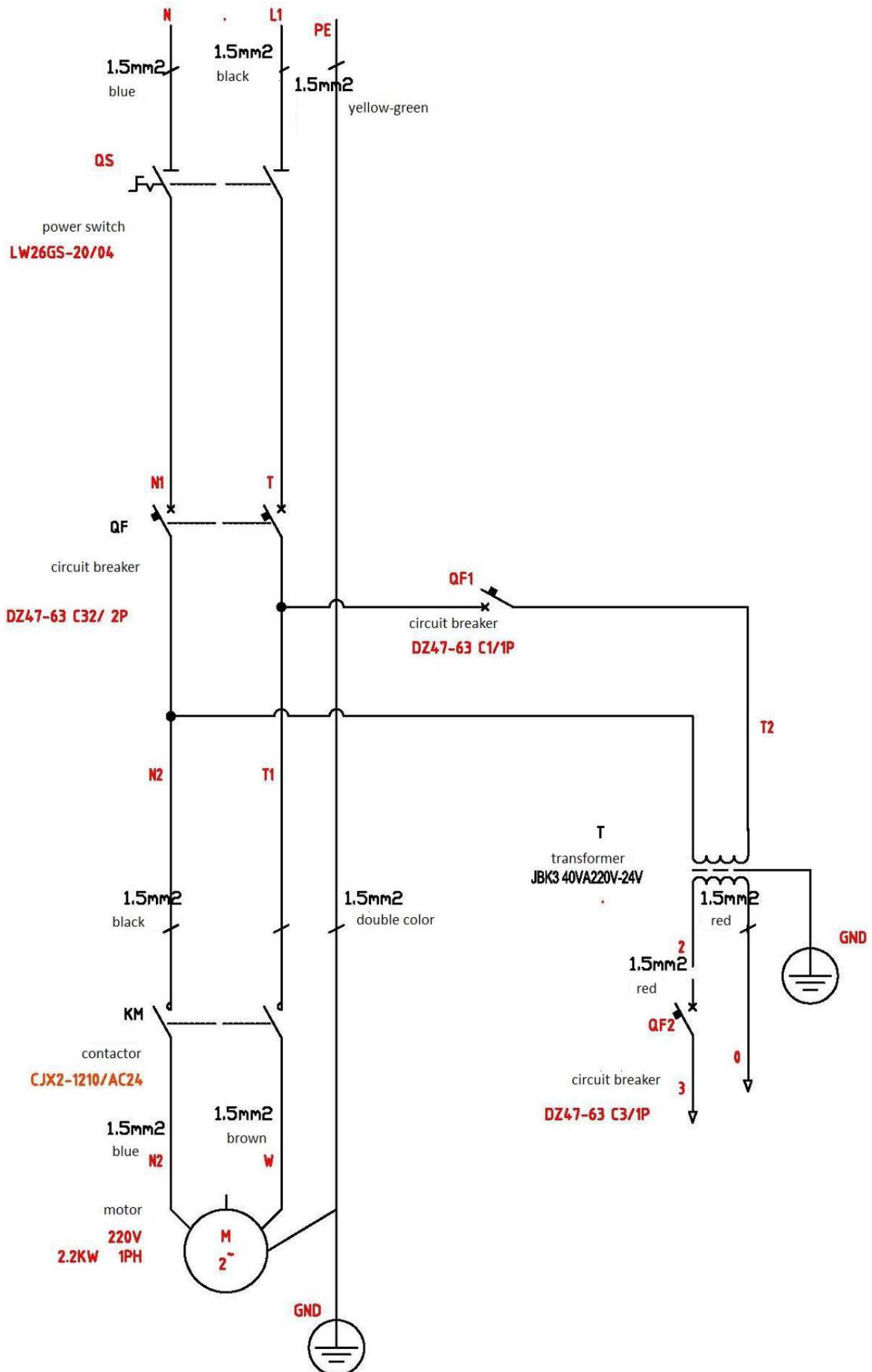

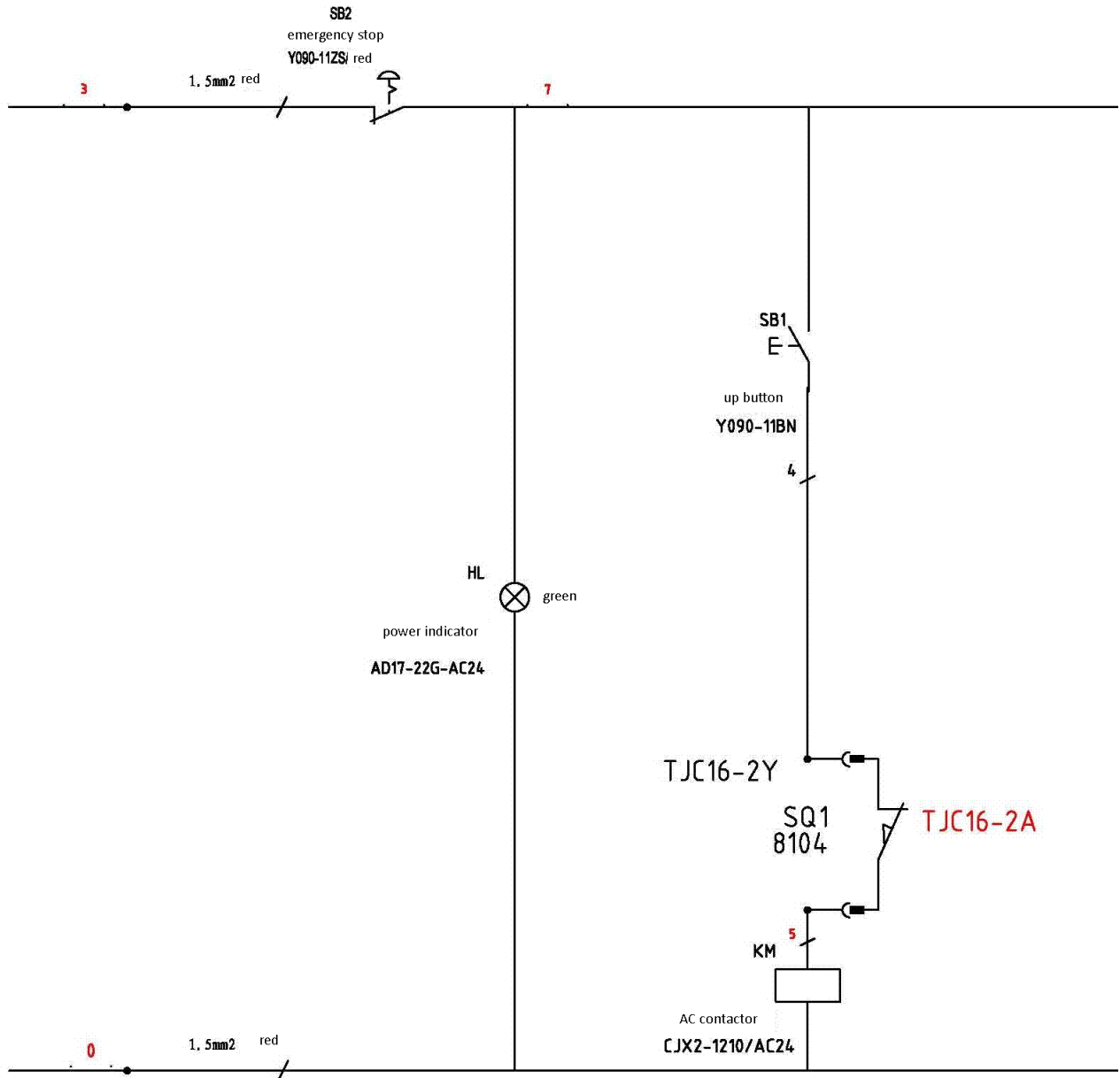

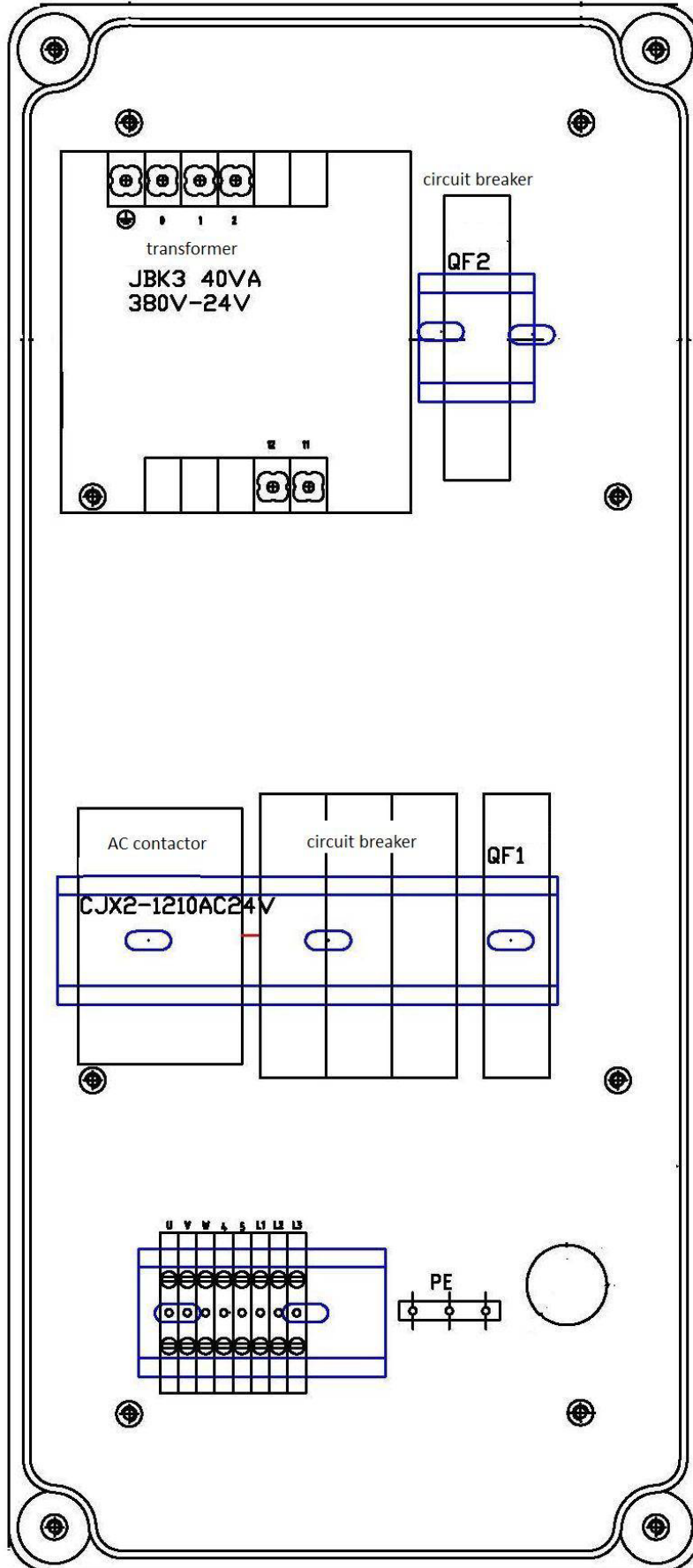



13.5 Detailed drawing and parts description of the lifting platform

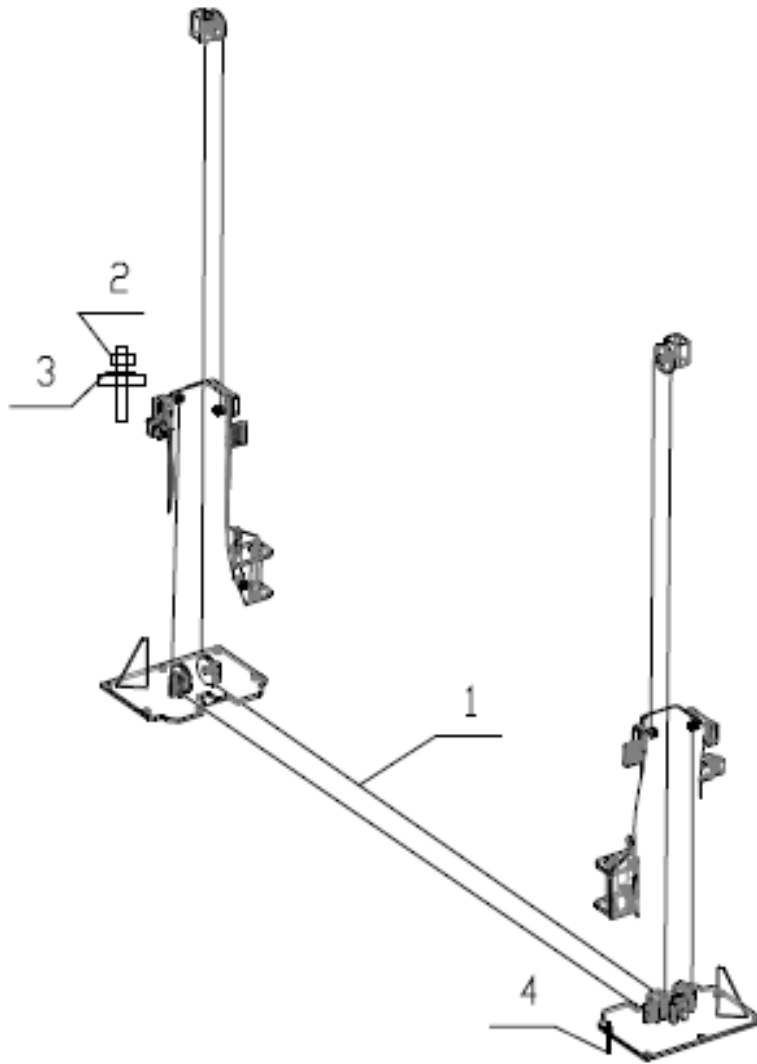

S/N	Name	Drawing	Qty	Property	Note
1	Steel cable L=8800 mm	FL-8223D-A6	2	Assembly	
2	Hex nut M16	GB/T6170-2000	8	Standard	
3	Class C flat washer M16	GB/T95-1985	4	Standard	
4	Expansion bolt M16*173		10	Standard	

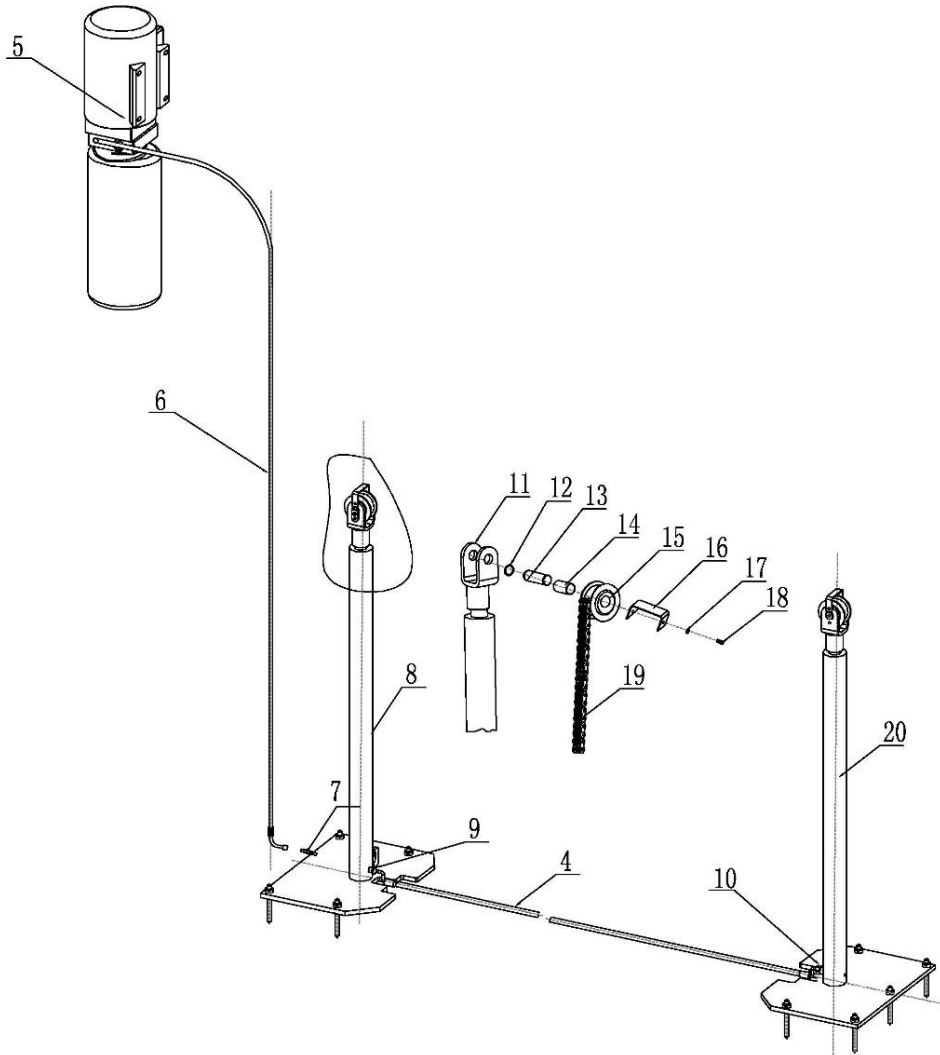

S/NN	Name	Drawing	Qty	Property	Note
4	Rubber oil hose L=2900		1	Assembly	
5	Power unit		1	Assembly	
6	Rubber oil hose L=1300		1	Assembly	
7	Long connector		2	Assembly	
8	Drive oil cylinder	FL-8224T-A4-B2	1	Assembly	
9	Main connector		1	Zinc-plating	
10	Short connector		1	Zinc-plating	
12	Type B circlip 25	GB/T894.2-1986	4	Standard	
13	Chain wheel shaft	FL-8224-A4-B11	2	Zinc-plating	
14	Bearing 2548	SF-1	2	Standard	
15	Chain wheel	FL-8224-A4-B10	2	Zinc-plating	
16	Retaining plate	FL-8224-A4-B12	2	Zinc-plating	
17	Spring washer M6	GB/T93-1987	4	Standard	
18	Hex socket cylinder head screw M6*10	GB/T70.1-2000	4	Standard	
19	Chain	LH1234-127LGB/6074-1995	2	Standard	
20	Oil cylinder	FL-8224T-A4-B3	1	Assembly	

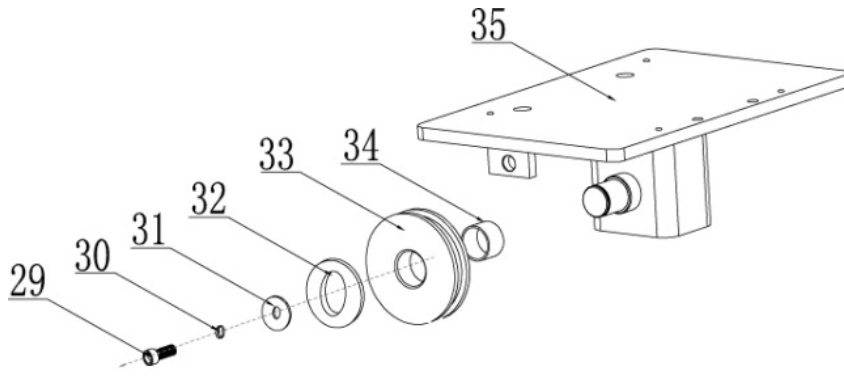

S/	Material	Name	Drawing	Qty	Property	Note
29		Hex socket button head screw M8*20	GB/T70.2-2000	2	Standard	
30		Spring washer M8	GB/T93-1987	2	Standard	
32		Washer	GB/T894.2-1986	2	Zinc-plating	
33		UP pulley	FL-8224T-A1-B2	2	Zinc-plating	
34		Bearing 2516	SF-1	2	Standard	
35		Top cover	FL-8224-A1-B3-C1	2	Welded	

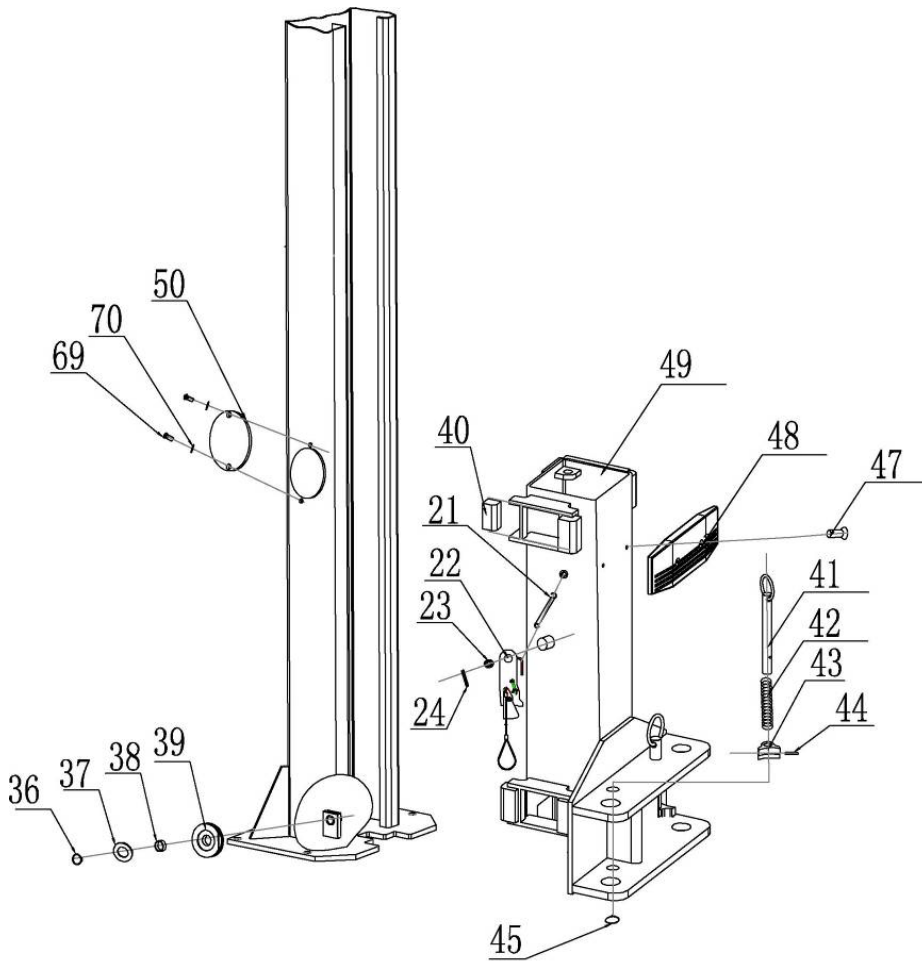

S/N	Name	Drawing	Qty	Property	Note
21	Tension spring	FL-8224-A3-B8	2	65Mn	
22	Safety lock assembly	FL-8224-A3-B3	2	Assembly	
23	Sheath			Q235A	
24	Cotter pin 3*45	GB/T879.1-2000	2	Standard	
36	Type B circlip 25	GB/T894.2-1986	4	Standard	
38	Bearing 2516	SF-1	4	Standard	
39	Down pulley	FL-8224-A1-B3	4	Q235A	
40	Slider	FL-8224T-A3-B2	16	Nylon 1010	
41	Pulling rod	FL-8224-A3-B2	4	Welded	
42	Pressure spring	FL-8224-A3-B5	4	Zinc-plating	
43	Teeth block	FL-8224-A3-B4	4	Q235A	
44	Elastic cylindrical pin 5*35	GB/T879.1-2000	4	Standard	
45	Type B circlip 25	GB/T894.2-1986	2	Standard	
47	Cross socket sunken head screw M8*16	GB/T819.1-2000	4	Standard	
48	Protection rubber pad	FL-8224-A3-B7	2	Rubber	
49	Carriage	FL-8223D-A3-B1	2	Assembly	
50	Cover plate	FL-8224-A1-B5	2	Q235A	
69	Cross socket cap head screw M6*8	GB/T818-2000	4	Standard	
70	Class C flat washer M6	GB/T95-1985	4	Standard	

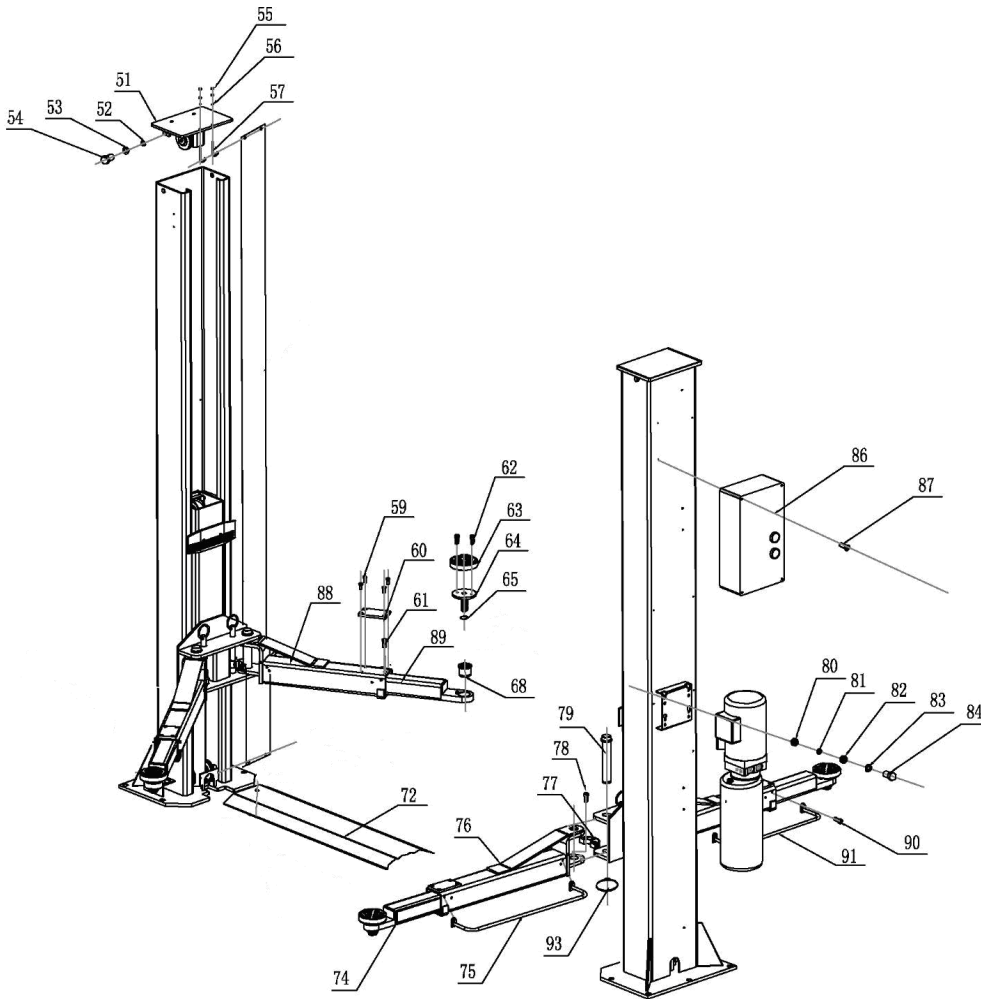

S/N	Name	Drawing	Qty	Property	Note
51	Top plate	FL-8224T-A1-B3	2	Assembly	
52	Class C flat washer M12	GB/T95-1985	4	Standard	
53	Spring washer M12	GB/T93-1987	4	Standard	
54	Hex head full swivel screw M12*20	GB/T5781-2000	4	Standard	
55	Hex nut M6	GB/T6170-2000	8	Standard	
56	Class C flat washer M6	GB/T95-1985	4	Standard	
57	Rod of chain protection cloth	FL-8224-A13	4	Standard	
59	Cross socket flat head screw M5*10	GB/T819.1-2000	16	Standard	
60	Square lifting pad	FL-8224-A7-B6	4	Rubber	
61	Cross socket flat head screw M8*10	GB/T819.1-2000	4	Standard	
62	Hex socket flat head screw M8*20	GB/T70.3-2000	8	Standard	
63	Round lifting pad	FL-8224-A7-B3-C4	4	Rubber	
64	Lifting tray	FL-8224T-A7-B3-C1	4	Welded	
65	Type B circlip 22	GB/T894.2-1986	4	Standard	
68	Inside swivel sheath	FL-8224-A7-B3-C3	4	Q235A	

S/N	Name	Drawing	Qty	Property	Note
72	Base cover plate	FL-8224-A10	1	Q235A	
74	Long tensile arm	FL-8224-A7-B1	2	Welded	
75	Long fender	FL-8224-A7-B4	2	Welded	
76	Long arm	FL-8224-A7-B2	2	Welded	
77	Teeth block	FL-8224-A7-B5	4	Q235A	
78	Hex socket cylinder head screw M10*20	GB/T70.1-2000	12	Standard	
79	Pin	FL-8224-A12	4	Welded	
80	Hex nut M10	GB/T6170-2000	4	Standard	
81	Spring washer M10	GB/T93-1987	4	Standard	
82	Anti-shock pad	FL-8224-A14	4	Rubber	
83	Class C flat washer M10	GB/T95-1985	4	Standard	
84	Hex head full swivel screw M10*35	GB/T5781-2000	4	Standard	
86	Control box		1	Assembly	
87	Cross socket cap head screw M5*10	GB/T818-2000	4	Standard	
88	Short arm	FL-8224-A8-B1	2	Welded	
89	Short tensile arm	FL-8224-A8-B2	2	Welded	
90	Hex socket button head screw M8*12	GB/T70.2-2000	8	Standard	
91	Short fender	FL-8224-A8-B3	2	Welded	

**13.6 Spare parts list**

S/N	Name	Spec.	Qty	Pic.	Note
1	Power switch	LW26GS-20/04	1		
2	Button	Y090-11BN	3		
3	Power indicator	AD17-22G-AC24	1		
4	Transformer	JBK-40VA220V-24V	1	Same as item 7	
5	Transformer	JBK-40VA230V-24V	1	Same as item 7	
6	Transformer	JBK-40VA240V-24V	1	Same as item 7	
7	Transformer	JBK-40VA380V-24V	1		
8	Transformer	JBK-40VA400V-24V	1	Same as item 7	
9	Transformer	JBK-40VA415V-24V	1	Same as item 7	
10	AC contactor	CJX2-1210/AC24	1		
11	Circuit breaker	DZ47-63 C16 /3P	1		
12	Circuit breaker	DZ47-63 C32 /2P	1		
13	Circuit breaker	DZ47-63 C1 /1P	1		
14	Circuit breaker	DZ47-63 C3 /1P	1	Same as item 13	
15	Limit switch	TZ8108	1		
16	Control box	Big	1		

**Mechanical spare parts**

S/N	Name	Drawing#	Qty	Property	Note
1	Slider	FL-8224T-A3-B2	16	Nylon 1010	
2	Rubber lifting pad	FL-8224-A7-B3-C4	4	Rubber	
3	Y-shape seal ring	(∅-inside)23.6*3.55	1		
4	O-shape seal ring	KD 63*48*10	1		
5	Anti-dust ring	DHS 40*48*5/6.5	1		



## Conversions and major repairs

Kind	Date / Name









The company

**Twin Busch GmbH | Amperestr. 1 | D-64625 Bensheim**

hereby declares that the **2-post vehicle lift**

**TW236M-400, TW236M-230, TW236M-400-FZ, TW236M-230-FZ,  
TW242M-400, TW242M-230, TW242M-400-FZ, TW242M-230-FZ,  
TW242GM-400, TW242GM-230 | 3.600 kg, 4.200 kg**

Serial number:

in these configurations we have placed on the marked complies with the relevant essential health and safety requirements of the following EC-directive(s) in its/their current version(s).

EC-directive(s)

**2006/42/EC**

**Machinery**

**2014/35/EU**

**Low Voltage**

Applied harmonized standards and regulations

**EN 1493:2022**

**Vehicle Lifts**

**EN 60204-1:2018**

**Safety of Machinery – Electrical Equipment of Machines**

CE Certificate

**M6A 087411 0079 Rev. 00**

date of issue: 09.08.2023

**N8MA 087411 0078 Rev. 00**

place of issue: München

technical file no.: 646642303401

Certification body

TÜV SÜD Product Service GmbH,

Ridlerstraße 65,

D-80339 München

Notified Body Appointment No.: 0123

**In the case of improper use, as well as in the case of assembling, modification or changes which are not agreed with us, this declaration will lose its validity.**

Authorized person to compile technical documentation is: Michael Glade (adress as below)



**TWIN BUSCH GmbH**  
Amperestr. 1 · 64625 Bensheim  
Tel. 06251 / 70585-0 · Fax: 70585-29

Authorized signatory: Michael Glade  
Bensheim, 07.11.2023 Qualitätsmanagement

**Twin Busch GmbH | Amperestr. 1 | D-64625 Bensheim**

**twinbusch.de | E-Mail: info@twinbusch.de | Tel.: +49 (0)6251-70585-0**



*You can find more products at:*

***[twinbusch.co.uk](http://twinbusch.co.uk)***

---

**Twin Busch UK LTD**  
Kettering  
Northants NN16 8PS

Tel.: +44 (0) 1536 522 960  
E-Mail: [info@twinbusch.co.uk](mailto:info@twinbusch.co.uk)  
Web: [www.twinbusch.co.uk](http://www.twinbusch.co.uk)

The technical specifications and illustrations provided in the user manual are not binding. Our products are subject to technical changes, so the delivered condition may vary.